

LABORATORY EXERCISES  
IN CHEMISTRY  

---

NEWELL

QD

45

.N548

FT MEADE

GenColl

D. C. HEATH & COMPANY



Class Q D 45

Book N 548

Copyright N<sup>o</sup> \_\_\_\_\_

**COPYRIGHT DEPOSIT**

GPO











# LABORATORY EXERCISES

FOR A

# BRIEF COURSE IN CHEMISTRY

BY

LYMAN C. NEWELL

PROFESSOR OF CHEMISTRY, BOSTON UNIVERSITY, BOSTON, MASS.

AUTHOR OF

“EXPERIMENTAL CHEMISTRY,” “DESCRIPTIVE CHEMISTRY,”

“GENERAL CHEMISTRY,” “PRACTICAL CHEMISTRY”



D. C. HEATH AND COMPANY

BOSTON

NEW YORK

CHICAGO

ATLANTA

SAN FRANCISCO

DALLAS

LONDON

QD45  
N548

COPYRIGHT, 1927,  
BY LYMAN C. NEWELL.

2 F 7

© CIA999102

PRINTED IN U.S.A.

JUL 22 '27

7-2-57  
M. V. G.

## PREFACE

THIS book contains laboratory exercises for a brief course in chemistry. The exercises are divided into two groups — minimum and supplementary. Each group is numbered separately.

The minimum group consists mainly of the exercises suggested by a Committee of the American Chemical Society as a minimum laboratory requirement for a year of chemistry. Besides the suggested exercises, this group contains a few others, some for the pupil and some for the teacher. On page xi there is an annotated list (LIST A) of the exercises for a minimum course.

The supplementary group contains these kinds of exercises : —

(1) Exercises which may be substituted for corresponding ones in the minimum group.

(2) Exercises desirable for a course longer than the minimum.

(3) Exercises needed for pupils who can do extra laboratory work.

(4) Exercises suitable for demonstration by the teacher.

On page xi there is an annotated list (LIST B) of the supplementary exercises.

This book has three new and distinctive features.

(1) Questions are omitted from the laboratory exercises.

(2) Instead of questions, precise directions for observing essential results are inserted in the proper places.

(3) At the close of each laboratory exercise there are specific instructions for writing the notes.

This plan of directed observing and specific recording will produce more satisfactory laboratory work and more accu-



rate laboratory records. Moreover, this plan will lighten the teacher's task of examining laboratory note books — a desirable and welcome relief.

The apparatus needed for most of the exercises is simple. Many pieces are interchangeable and are used frequently. In some exercises a choice of apparatus is offered.

The introductory pages (1-2) contain some general directions needed at the outset by the pupil.

The APPENDIX contains detailed directions for general laboratory processes, a brief treatment of the metric system of weights and measures, and full lists of the necessary apparatus, chemicals, and other supplies.

LYMAN C. NEWELL

BOSTON, MASS.,  
April, 1927.

# CONTENTS

Numbers indicate exercises. Supplementary exercises are marked S. Teacher's exercises are marked T. Essential exercises are marked ★. See Suggestions for Teachers on page xi.

	PAGE
SUGGESTIONS FOR TEACHERS . . . . .	xi
GENERAL DIRECTIONS FOR THE PUPIL . . . . .	1
Apparatus — Laboratory notebook — Doing laboratory exercises.	
PROPERTIES — CHEMICAL CHANGE — MIXTURE	
— COMPOUND . . . . .	3
1 — Properties and Chemical Change . . . . .	3
★ 2 — Mixture and Compound . . . . .	4
S 1 — Decomposition of Mercuric Oxide . . . . .	6
OXYGEN . . . . .	7
★ 3 — Preparation and Properties of Oxygen . . . . .	7
4 — Heating a Known Weight of a Metal in Air . . . . .	9
S 2 — Examples of Chemical Change in Exercise 3 . . . . .	11
S 3 — Preparation of Oxygen (Short Method) . . . . .	12
S 4 — Preparation of Copper Oxide . . . . .	13
S 5 — Slow and Rapid Oxidation — T . . . . .	14
CARBON . . . . .	15
★ 5 — Properties of Charcoal . . . . .	15
★ 6 — Reduction of Copper Oxide by Carbon . . . . .	16
★ 7 — Preparation and Properties of Carbon Dioxide . . . . .	17
8 — Preparation and Properties of Carbon Monoxide — T . . . . .	18
S 6 — Combustion and Carbon Dioxide . . . . .	20
S 7 — A Fire Extinguisher and Carbon Dioxide — T . . . . .	21

	PAGE
HYDROGEN . . . . .	22
★ 9 — Preparation and Properties of Hydrogen . . . . .	22
★ 10 — Reduction of Copper Oxide by Illuminating Gas . . . . .	24
★ 11 — Reaction between Sodium and Water — T . . . . .	25
S 8 — Preparation of Hydrogen (Short Method) . . . . .	27
S 9 — Reaction between Zinc and Sulfuric Acid — T . . . . .	28
S 10 — Reduction of Copper Oxide by Hydrogen — T . . . . .	29
WATER . . . . .	30
12 — Purifying Water by Distillation . . . . .	30
★ 13 — Suspension and Solution of Solids in Water . . . . .	31
★ 14 — Effect of Heat on the Solubility of Solids . . . . .	32
★ 15 — Formation of Crystals . . . . .	33
★ 16 — Effect of Shape on the Solubility of a Solid — T . . . . .	33
★ 17 — Testing Crystals for Water of Hydration . . . . .	33
★ 18 — Per Cent of Water of Hydration . . . . .	34
19 — Electrolysis of Water (Acid Solution) — T . . . . .	35
S 11 — Preparation and Properties of Distilled Water — T . . . . .	37
S 12 — Purification of Water — T . . . . .	39
S 13 — Anhydrous Compounds . . . . .	39
S 14 — Efflorescence — T . . . . .	40
S 15 — Efflorescence and Deliquescence — T . . . . .	40
S 16 — Supersaturated Solution — T . . . . .	41
S 17 — Qualitative Composition of Water — T . . . . .	42
EQUIVALENT WEIGHTS — FORMULA . . . . .	42
20 — Equivalent Weight of Zinc . . . . .	42
★ 21 — Equivalent Weight of Magnesium . . . . .	45
22 — Formation of the Compound Copper Sulfide . . . . .	46
S 18 — Equivalent Weight of Aluminum . . . . .	48
CHLORINE AND HYDROCHLORIC ACID . . . . .	48
★ 23 — Preparation and Properties of Chlorine . . . . .	48
★ 24 — Hydrogen Chloride and Hydrochloric Acid . . . . .	50
★ 25 — Tests for Hydrochloric Acid and Chlorides . . . . .	52
★ 26 — Insoluble Chlorides . . . . .	53
S 19 — Preparation and Properties of Chlorine — T . . . . .	53
S 20 — Chlorine Water — T . . . . .	54

# CONTENTS

vii

	PAGE
S 21 — Bleaching with Bleaching Powder — T . . . . .	55
S 22 — Hydrogen Chloride . . . . .	55
S 23 — Aqua Regia — T . . . . .	56
S 24 — Types of Chemical Change — T . . . . .	56
<b>AIR — NITROGEN . . . . .</b>	<b>57</b>
27 — Per Cent of Oxygen in Air — T . . . . .	57
S 25 — Air and Combustion . . . . .	59
S 26 — Water Vapor and Carbon Dioxide in Air . . . . .	59
S 27 — Preparation and Properties of Nitrogen — T . . . . .	60
<b>ACIDS, BASES, AND SALTS . . . . .</b>	<b>61</b>
★ 28 — Behavior of Oxides with Water . . . . .	61
29 — Neutralization . . . . .	62
30 — Neutralization by Titration — T . . . . .	63
31 — Preparation of Salts . . . . .	66
S 28 — General Properties of Acids . . . . .	67
S 29 — General Properties of Bases . . . . .	68
S 30 — Two Properties of Many Salts . . . . .	68
<b>IONIZATION AND IONS . . . . .</b>	<b>69</b>
32 — Electrolytes and Non-Electrolytes — T . . . . .	69
33 — Electrolysis of Copper Sulfate Solution — T . . . . .	70
34 — Reversible Reactions . . . . .	70
35 — Colored and Colorless Ions — T . . . . .	71
S 31 — Electrolysis of Copper Sulfate Solution (Short Method) — T . . . . .	72
S 32 — Electrolysis of Sodium Sulfate Solution — T . . . . .	72
S 33 — Testing for Ions . . . . .	73
S 34 — Hydrolysis of Certain Salts . . . . .	74
<b>AMMONIA . . . . .</b>	<b>74</b>
★ 36 — Preparation and Properties of Ammonia . . . . .	74
S 35 — Preparation of Ammonia from Various Substances . . . . .	76
<b>NITRIC ACID — NITROGEN OXIDES . . . . .</b>	<b>77</b>
37 — Preparation of Nitric Acid — T . . . . .	77
★ 38 — Properties of Nitric Acid . . . . .	78
★ 39 — Nitric Oxide and Nitrogen Dioxide . . . . .	79

	PAGE
★ 40 — Test for Nitric Acid and Nitrates . . . . .	80
S 36 — Nitrous Oxide — T . . . . .	81
MOLECULAR WEIGHTS . . . . .	82
41 — Weight of 22.4 Liters of Oxygen . . . . .	82
SULFUR . . . . .	85
★ 42 — Different Forms of Sulfur . . . . .	85
★ 43 — Sulfur Dioxide (Short Method) . . . . .	86
44 — Sulfur Dioxide and Sulfurous Acid — T . . . . .	87
★ 45 — Properties of Sulfuric Acid . . . . .	89
★ 46 — Test for Sulfuric Acid, Sulfates, SO <sub>4</sub> -ions . . . . .	90
★ 47 — Hydrogen Sulfide (Short Method) . . . . .	91
S 37 — Hydrogen Sulfide — T . . . . .	92
S 38 — Sulfides — T . . . . .	93
CARBON — FLAME . . . . .	94
★ 48 — Distillation of Soft Coal . . . . .	94
★ 49 — Distillation of Wood — T . . . . .	95
★ 50 — Illuminating Gas Flame — T . . . . .	96
★ 51 — Candle Flame — T . . . . .	97
★ 52 — Bunsen Burner and Flame — T . . . . .	98
★ 53 — Reduction and Oxidation with the Blowpipe . . . . .	100
S 39 — Carbonic Acid — T . . . . .	101
S 40 — Acetylene — T . . . . .	102
ORGANIC COMPOUNDS . . . . .	103
54 — Sugars . . . . .	103
55 — Starch . . . . .	104
56 — Testing Baking Powders . . . . .	104
S 41 — Esters . . . . .	106
S 42 — Soap . . . . .	107
S 43 — Nutrients in Food — T . . . . .	108
BROMINE AND IODINE . . . . .	109
S 44 — Preparation and Properties of Bromine — T . . . . .	109
S 45 — Bromine (Short Method) . . . . .	110
S 46 — Tests for Free and Combined Bromine . . . . .	111



# CONTENTS

ix

	PAGE
S 47 — Preparation and Properties of Iodine — T . . . . .	112
S 48 — Iodine (Short Method) . . . . .	113
S 49 — Tests for Free Iodine . . . . .	113
S 50 — Tests for Combined Iodine . . . . .	113
 SODIUM . . . . .	 114
S 51 — Sodium Bicarbonate — T . . . . .	114
S 52 — Sodium Chloride — T . . . . .	115
 CALCIUM . . . . .	 116
★ 57 — Calcium Carbonate, Oxide, and Hydroxide . . . . .	116
★ 58 — Hardness of Water — T . . . . .	118
S 53 — Tests for Calcium in Compounds . . . . .	119
S 54 — Properties of Cement — T . . . . .	120
S 55 — Plaster of Paris — T . . . . .	121
 IRON . . . . .	 121
59 — Tests for Iron Salts . . . . .	121
60 — Reduction and Oxidation of Iron Salts . . . . .	122
 METALS — DISPLACEMENT AND TESTS . . . . .	 123
★ 61 — Displacement of Metals . . . . .	123
62 — Flame Tests for Metals . . . . .	123
S 56 — Tests for Metals . . . . .	124
S 57 — Tests with Borax Beads . . . . .	126
S 58 — Cobalt Nitrate Tests . . . . .	127
S 59 — Testing Salts for Metal and Non-Metal . . . . .	127
S 60 — Silver Salts and Photography — T . . . . .	128
S 61 — Aluminum Hydroxide . . . . .	129
S 62 — Qualitative Analysis (Lead, Silver, Mercury) . . . . .	130
 APPENDIX . . . . .	 133
Pressure of Water Vapor . . . . .	133
How to Use the Bunsen Burner . . . . .	133
Working with Glass Tubing . . . . .	134
Filtering . . . . .	136
Constructing and Arranging Apparatus . . . . .	137
Pouring Liquids and Transferring Solids . . . . .	139

## CONTENTS

	PAGE
Collecting Gases . . . . .	140
Weighing . . . . .	141
Measuring . . . . .	144
The Metric System . . . . .	144
Smelling and Tasting . . . . .	146
Accidents . . . . .	146
Laboratory Supplies . . . . .	146

## SUGGESTIONS FOR TEACHERS

THE author does not intend that all the exercises in this book shall be performed by each pupil in the time allotted to a first course in chemistry. The lists given below contain the exercises recommended for two courses — minimum and brief, and should be followed without much change. The few exercises not included may be used to meet special needs.

### LIST A — MINIMUM COURSE

This list includes the exercises for a minimum, well-balanced course covering a year. Essential exercises are starred. Exercises which should be done by the teacher are marked T. Supplementary exercises are marked S.

Numbers 1, \*2, \*3 (or \*S3), 4, S5-T, \*5, \*6, \*7, 8-T, \*9 (or \*S8), \*10 (or S10-T), 11-T, 12 (or S11-T), \*13, \*14, \*15, 16-T, 17-T, \*18 (A or B), S15-T, 19-T, \*21 (or 20, S18), 22 (may be omitted), \*23 (or S19-T), \*24 (or S22), \*25, \*26, \*27-T, \*28, 29, 30-T, \*31, 32-T, 33-T, S33, 34, 35-T, \*36 (or S35), 37-T, \*38, \*39, \*40, 41 (may be omitted), \*42, \*43 (or 44-T), \*45, \*46, 47, (or S37-T), \*48, \*49, \*50-T, \*51-T, \*52-T, \*53, 54, 55, 56, S42, S52, 57, \*58-T, 59, 60, \*61, 62.

### LIST B — BRIEF COURSE

The list includes most of the exercises in the minimum course together with selections from the supplementary exercises. Essential exercises are starred, exercises for teachers are marked T, and supplementary exercises are marked S.

Numbers \* 1, \* 2, \* 3, S2, S4, S5-T, \* 5, \* 6, \* 7, S6, S7-T, 8-T, \* 9, \* 10 (or S10-T), \* 11-T, \* 12 (or S11-T), \* 13, \* 14, \* 15, \* 16-T, \* 17, S13-T, \* 18, S14-T, S15-T, S16-T, S17-T, 19-T, \* 21 (or 20), S18, 22, \* 23 (or S19), \* 24 (or S22), \* 25, \* 26, S21-T, S23-T, S24-T, \* 27-T, S25, S26, S27-T, \* 28, S28, S29, \* 29, 30-T, \* 31, 32-T, 33-T (or S31-T), S32-T, \* S33, 34, 35-T, \* 36, 37-T, \* 38, \* 39, \* 40, 41, \* 42, \* 43 (or 44-T), \* 45, \* 46, 47 (or S37-T and S38-T), \* 48, \* 49, \* 50-T, \* 51-T, \* 52-T, 53, S49-T, 54, 55, 56, S41, S42, S46, \* 49, S50, S51-T, 57, \* 58-T, S54-T, S55-T, 59, 60, \* 61, 62, S56, S57, S58.





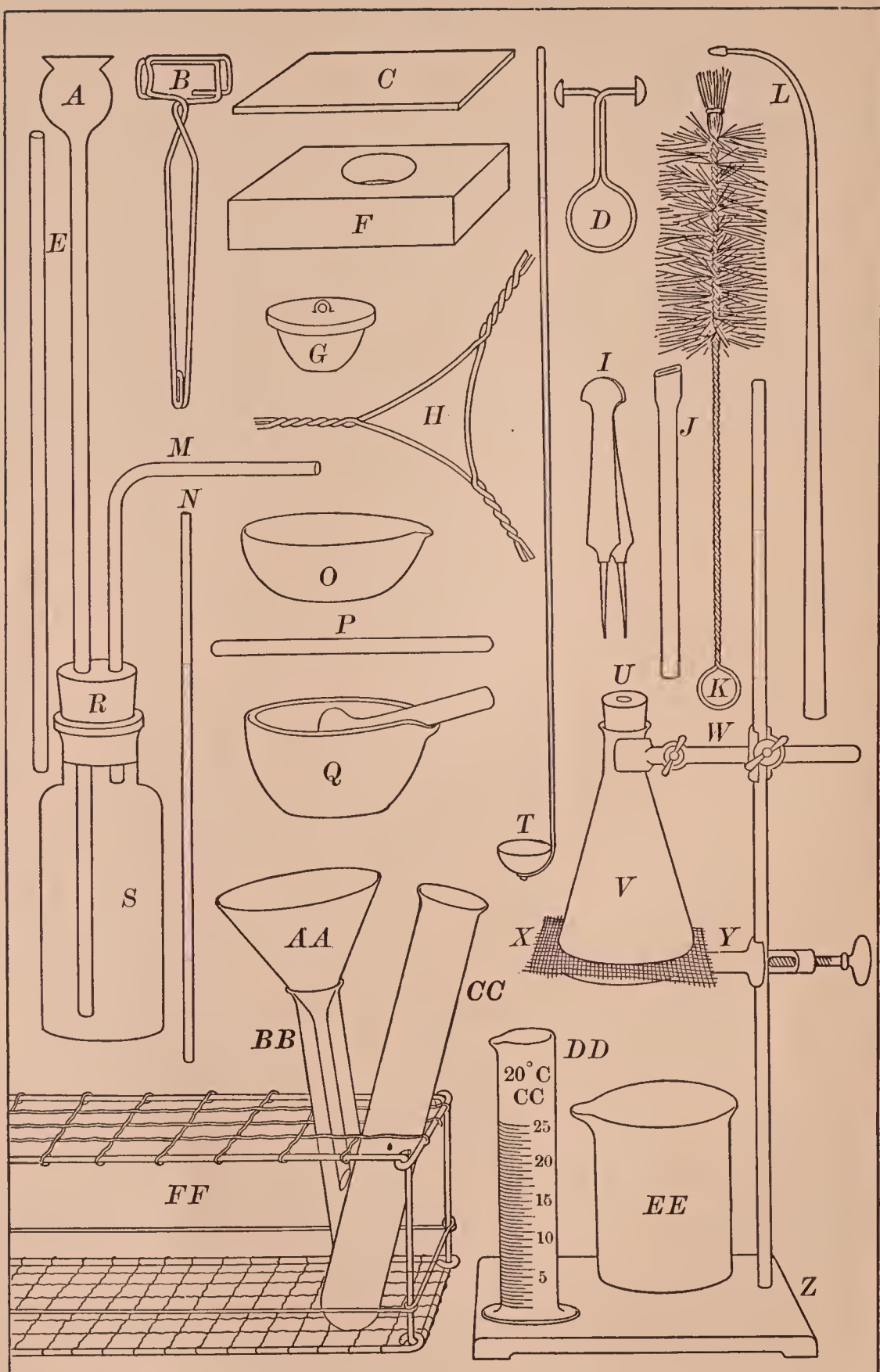

Apparatus frequently used in the laboratory

# LABORATORY EXERCISES

FOR A

## BRIEF COURSE IN CHEMISTRY

### GENERAL DIRECTIONS FOR THE PUPIL

**1. Apparatus.** — The apparatus frequently used is shown in the figure on the opposite page.

*A* — Thistle tube. *B* — Test tube holder. *C* — Glass plate. *D* — Pinch clamp. *E* — Glass tube. *F* — Crucible block. *G* — Porcelain crucible (covered). *H* — Triangle. *I* — Forceps. *J* — Blowpipe tube. *K* — Test tube brush. *L* — Blowpipe. *M* — Right-angle bend. *N* — Glass rod. *O* — Porcelain evaporating dish. *P* — Glass plug. *Q* — Mortar and pestle. *R* — Rubber stopper (2-hole). *S* — Bottle. *T* — Deflagrating spoon. *U* — Rubber stopper (1-hole). *V* — Erlenmeyer flask. *W* — Iron clamp. *X* — Wire gauze. *Y* — Iron ring. *Z* — Iron stand. *AA* — Funnel. *BB* — Test tube (small). *CC* — Test tube (large). *DD* — Graduated cylinder. *EE* — Beaker. *FF* — Test tube rack (in part).

Use this figure to identify the unfamiliar apparatus in your desk. When your set of apparatus agrees with the list, sign and hand the completed list to the Teacher.

Some general apparatus, *e.g.* scales, is kept in the laboratory, and special apparatus will be supplied as needed.

Besides the apparatus in your desk, you will need a rubber apron and a pair of sleeves, or something similar, to protect your clothes.

**2. Laboratory notebook.** — You will need a laboratory notebook. Write your name and the number of your desk on the cover of the notebook. In this book you should keep a neat and accurate account of all the laboratory exercises you perform. In general, your record should include: —

(1) The number and title of the exercise and the date.

(2) A brief account in your own words of the exercise as you did it.

(3) Answers to all questions — not merely yes or no, but a brief answer based on your own work.

(4) Answers or records by the numbers and letters which correspond to those in the directions, *e.g.* 1, I, (1), (a), etc.

(5) All numerical data, *e.g.* weights and volumes, in the form required by the directions.

(6) Equations wherever they are asked or will make the notes clearer.

(7) A simple sketch of the apparatus (if time permits).

**3. Doing laboratory exercises.** — To do laboratory exercises successfully, you must meet certain requirements.

(1) **Before the laboratory period** find out what exercises are to be done, read the directions carefully, and plan the work as well as you can.

(2) **When you enter the laboratory**, open your desk at once, or have it opened, take out the necessary apparatus, and begin to work without delay.

(3) **When you are doing an exercise in the laboratory**, follow the directions carefully, especially about quantities of chemicals, heating, and weighing; work and think independently. If you need assistance, ask the Teacher.

(4) **Learn as soon as possible:**

(a) The name of each piece of apparatus, and how to use it.

(b) How to perform skillfully the operations frequently done in the laboratory (see APPENDIX §§ 2, 4, 5, 6, 7, 8).

(c) How to set up apparatus quickly and correctly.

(d) How to do arithmetical work rapidly and accurately, and to check results.

(5) **Before you leave the laboratory**, be sure your apparatus is clean and put away, the water and the gas are turned off, and your desk is clean.



# LABORATORY EXERCISES

## PROPERTIES — CHEMICAL CHANGE — MIXTURE — COMPOUND

### Exercise 1 — Properties and Chemical Change

**MATERIALS.** — Sulfur, magnesium ribbon.

**APPARATUS.** — Block of wood, forceps, Bunsen burner.

(a) Examine a piece of sulfur. Note its properties, especially the color. Put a small piece on a block of wood and heat it with a flame. Observe at once how the sulfur behaves; note especially the color of the flame. Note *very cautiously* the odor of the product by brushing a little gently toward the nose. Then extinguish the flame by pressing a piece of paper upon the burning sulfur.

(b) Examine a piece of magnesium ribbon. Note its color, appearance (*e.g.* luster), and flexibility. Grasp one end with the forceps, and hold the other end in the hottest part of the Bunsen flame until the magnesium undergoes a definite change (Fig. 1).

Remove at once and examine the product. Compare with unheated magnesium as to color, luster, and flexibility.

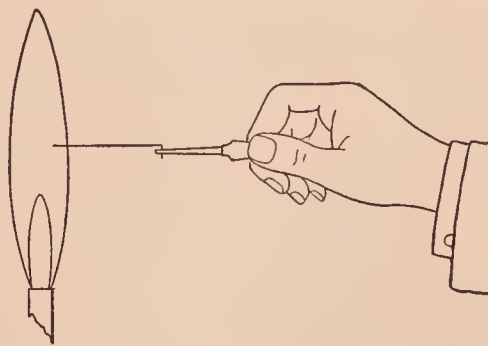

FIG. 1. — Heating magnesium in a Bunsen flame

*Write in your laboratory notes the properties of (a) sulfur and (b) magnesium.*

*Write also the evidence of chemical change when (a) sulfur and (b) magnesium are heated.*

## Optional Exercises

1. State one conspicuous property of sulfur. Of magnesium.
2. How does this exercise illustrate chemical change?

### ★Exercise 2 — Mixture and Compound

**MATERIALS.** — Powdered sulfur, powdered iron (or clean, fine iron filings), dilute hydrochloric acid, carbon disulfide.

**APPARATUS.** — Scales, magnet, lens, test tubes and holder, Bunsen burner, mortar and pestle.

**A.** Weigh about 4 gm. of powdered sulfur on a piece of paper on the scales (see APPENDIX, § 8). Weigh about 7 gm. of powdered iron (or clean, fine iron filings) on another paper.

(a) Note and record their conspicuous properties. Try the effect of a magnet on each by moving it along the under side of the paper. Note each result.

(b) Put a pinch of each in separate test tubes, add a little dilute hydrochloric acid, and warm gently. Note the result in each case, especially the odor, if any, of the gas from the tube containing the iron.

(c) Put a pinch of each in separate test tubes, add about 5 cc. of carbon disulfide, and shake well. (**Caution.** Carbon disulfide catches fire readily. Do not use carbon disulfide near a flame.) Note the result, especially in the tube containing the sulfur.

**B.** Mix the rest of the sulfur and iron thoroughly by grinding them together in a mortar. Divide the mixture into two equal portions. Use one in (a) and the other in (b).

(a) Examine the mixture with a lens, and note if you can detect sulfur and iron. Try the effect of a magnet on some of the mixture, and note the result.

Divide this portion into two parts. (1) Put one part in a test tube, and add dilute hydrochloric acid. Warm the acid mixture gently until there is evidence of action, note the odor and compare with the odor from the iron and acid in A (b). (2) Put the other part in a test tube, add 5 cc. of carbon disulfide, shake well, let it settle, pour the liquid



into a dish, and stand the dish in the hood. When the carbon disulfide has evaporated, examine the solid product, and decide what it is.

(b) Put the other half of the mixture from **B** in a test tube, attach the holder, and heat (Fig. 2) until the mass begins to glow, then take the test tube out of the flame. Heat again intensely for a few minutes. Let the tube cool, hold it over the mortar, and break off the lower end with the pestle. Remove the product, and use it in (c).

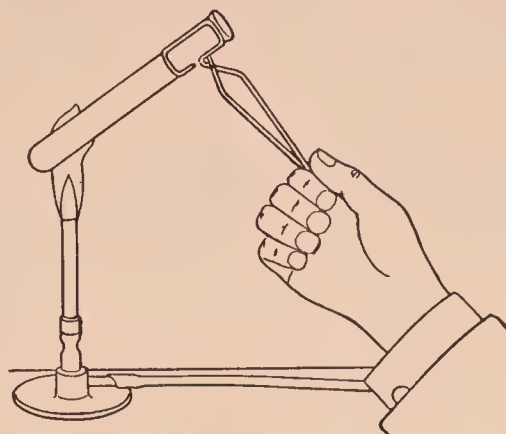

FIG. 2. — Heating a mixture of iron and sulfur in a test tube

(c) Examine the product from (b) with a lens, and note if iron or sulfur is detected. Try the effect of a magnet on a piece (from the outside), and note the effect.

Put a piece in a test tube, add a little hydrochloric acid, note the odor of the gas, and pour the contents immediately into a waste jar in the hood. Compare the odor of the gas with similar tests. Conclude as to the presence of (1) iron, or (2) a new substance.

Put a piece in another test tube, add 5 cc. of carbon disulfide, and shake well. As soon as the solid has settled, pour the liquid into a dish, stand the dish in the hood, and let the liquid evaporate. Note if any sulfur is left in the dish. Conclude as to the presence of sulfur in the product.

*Write a brief account of this exercise in your laboratory notes, stating clearly how this exercise shows the difference between a mixture and a compound.*

### Optional Exercises

1. What are some characteristics of a mixture? Of a compound?

2. Is the product in **B** (b) a mixture or a compound? Why?

## SUPPLEMENTARY EXERCISE ON COMPOUNDS

### Supplementary Exercise 1 — Decomposition of Mercuric Oxide

**MATERIALS.** — Mercuric oxide, joss stick (or small splint of wood).  
**APPARATUS.** — Test tube clamped to iron stand (Fig. 3). Bunsen burner.

Put a little mercuric oxide on the end of a narrow piece of paper creased lengthwise, and slip the powder into a test tube (Figs. 4, 5). The powder should nearly fill the round end of the test tube. Hold the test tube

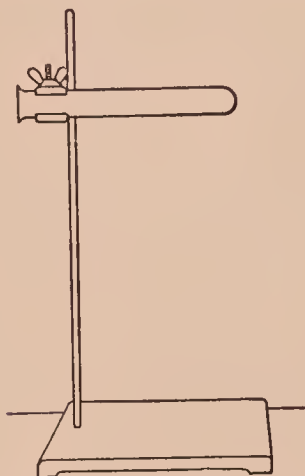

FIG. 3. — Apparatus for decomposing mercuric oxide

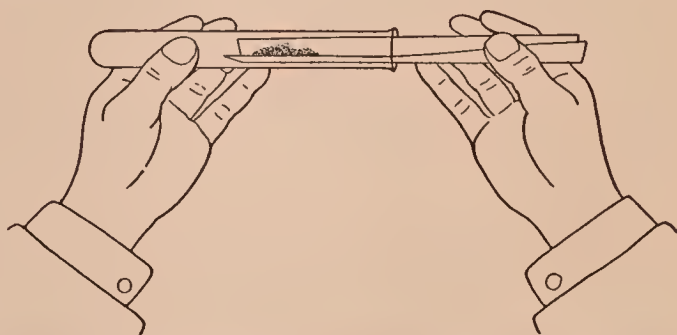

FIG. 4. — Putting a powder into a test tube — first step

in a horizontal position, shake it to spread the powder into a thin layer, and then clamp the test tube as in Fig. 3.

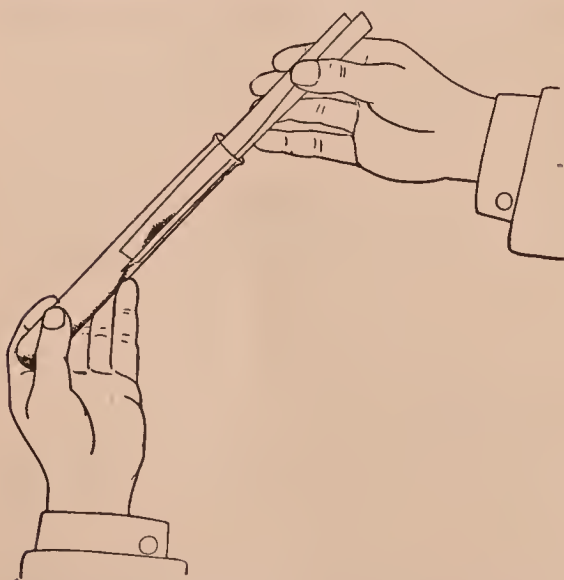

FIG. 5. — Putting a powder into a test tube — second step

(a) Heat the test tube gently at first; then heat intensely the part that contains the substance. After heating for several minutes insert a glowing joss stick well into the test tube. Observe the change in the joss stick. The change is due to oxygen. If there is no change, heat intensely and again insert the glowing joss stick.

(b) Examine the deposit on the upper part of the tube.

Conclude what it is. If you are in doubt, scrape out a little upon a piece of paper and examine it. (NOTE. — Some unchanged mercuric oxide will probably be left; throw it in the waste jar.)

*Write in your laboratory notes a brief account of this exercise.*

### Optional Exercises

1. To what class of substances does mercuric oxide belong?
2. To what class does the product from (a) belong? From (b)?
3. Into what substances can mercuric oxide be decomposed?

## OXYGEN

### ★Exercise 3 — Preparation and Properties of Oxygen

**MATERIALS.** — 5 gm. of potassium chlorate, 5 gm. of manganese dioxide, joss stick, sulfur, piece of charcoal fastened to one end of a copper wire (30 cm. long), wad of iron thread (“steel wool”).

**APPARATUS.** — As in Fig. 6. *A* is a large test tube (20 cm. or 8 in.) provided with a one-hole rubber stopper, to which is fitted a short glass tube *B*; the latter is connected by the rubber tube *C* with the delivery tube *D*. *E* is a pneumatic trough with a support for the collecting bottle *F*.

**I. Preparation.** — Weigh the potassium chlorate on the scales on a piece of paper creased lengthwise, and slip it into the test tube; do the same with the manganese dioxide. Shake

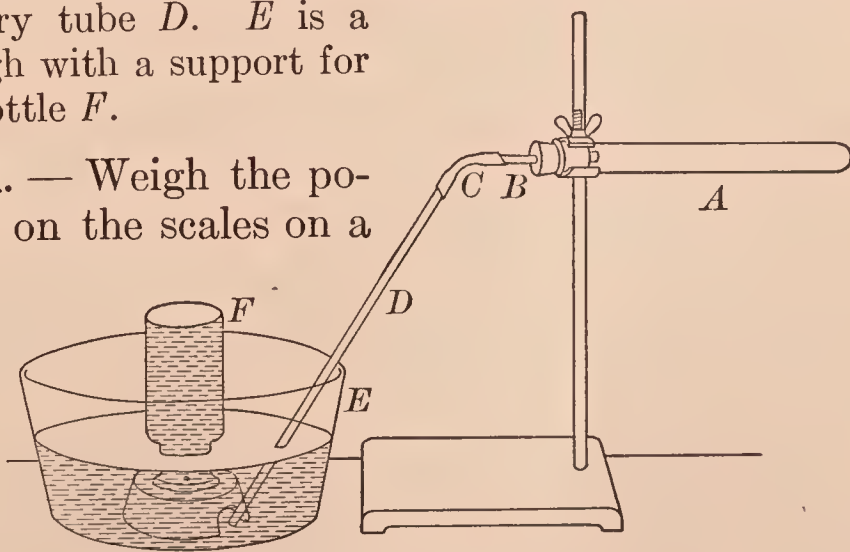

FIG. 6. — Apparatus for preparing oxygen

the test tube until the chemicals are thoroughly mixed. Hold the test tube in a horizontal position and roll or shake it until the mixture is spread along about one half of the



tube. Insert the stopper with its tubes, and clamp the test tube to the iron stand, as shown in Fig. 6. The end of the delivery tube *D* should rest on the bottom of the trough under the hole in the support.

Add water to the pneumatic trough *E* until the hole in the support is covered. Fill one bottle full of water, cover it with a piece of filter paper, invert it (Fig. 7), lower it into the water in the trough, remove the paper, and stand the inverted bottle *F* upon, or near, the support. Fill two more bottles and have them ready to replace the one in the trough.

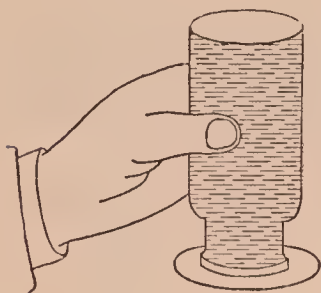

FIG. 7. — Inverted bottle full of water

Heat the test tube gently with a small Bunsen flame (about 10 cm. (4 in.) high). Move the flame slowly along the test tube, taking care not to heat the tube too long in one place nor too near the rubber stopper. As soon as the gas bubbles regularly through the water, slip the inverted bottle over the hole in the support. The gas will rise in the bottle and force out the water. If the gas comes off too rapidly, remove the flame for an instant; if too slowly, increase the heat; if not at all, examine the stopper and the rubber connecting tube for leaks, and adjust accordingly.

When the first bottle is full of gas, remove it, stand it (mouth upward) upon the desk, and cover it tightly with a piece of filter paper. Invert another bottle in the trough, remove the paper, and slip the bottle over the hole. Fill it with oxygen. Fill the other bottle in the same way. As soon as the last bottle of gas has been collected, immediately remove the end of the delivery tube *D* from the water. (NOTE. — Save the test tube *A* and contents for **Supplementary Exercise 2.**) Perform **II** at once.

**II. Properties.** — (*a*) Thrust a glowing joss stick into one bottle, and observe the result. Remove the joss stick, make it glow again, and repeat. Note (1) how the glowing joss stick changes, and (2) whether oxygen burns. Use this bottle of gas for (*b*).

(*b*) Put a small piece of sulfur in the deflagrating spoon, and heat it until the small, blue flame of burning sulfur is

seen. Then lower the spoon into the bottle of oxygen. Observe any change in the flame. *Very cautiously* waft a little of the contents of the bottle toward the nose and note the odor.

Remove the spoon and plunge it into the water in the trough to extinguish the burning sulfur. Fill the bottle one-fourth full of water, cover with the hand, and shake well. Cork tightly, and save for **Supplementary Exercise 2**.

(c) Heat the charcoal (fastened to the wire) long enough to produce a faint glow, then lower it into a bottle of oxygen. Observe the result.

Add limewater (about 10 cc.) to the bottle, shake well, and save as in (b).

(d) Twist one end of the copper wire (used in (c)) firmly around the wad of iron thread, heat the ends of a few strands for an instant, and quickly lower it into a bottle of oxygen. The iron should change conspicuously. Observe the result.

*Write in your laboratory notes (1) a very brief account of I and (2) brief statements of the observations made in II.*

### Optional Exercises

1. State some physical properties of oxygen, *e.g.* color, solubility in water.
2. State the chemical conduct of oxygen.
3. What is the test for oxygen?
4. Sketch the apparatus used to prepare oxygen.

### Exercise 4 — Heating a Known Weight of a Metal in Air

**MATERIAL.** — Zinc dust.

**APPARATUS.** — Crucible block (Fig. 8), crucible (Fig. 9), balance, weights, triangle, iron stand and ring.

Copy the form of **RECORD** (see below) in your laboratory notes. When you weigh, take the book, or sheet, containing this **RECORD** to the balance (or scales) and enter all weights in the proper place as soon as the weighing is made.

Clean and dry a porcelain crucible and cover. Place the covered crucible on the crucible block (Fig. 8), and carry it to the balance (or scales); always use this block in carrying the crucible to and from the balance (or scales). Weigh the covered crucible (ask for directions or follow directions in APPENDIX, § 8). Enter the weight in the RECORD.

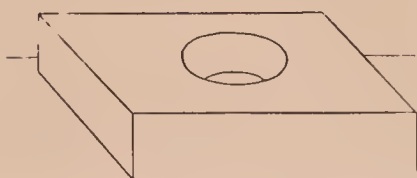

FIG. 8. — Block for carrying a crucible

### RECORD

Wt. of covered crucible and zinc . . . . .	gm.
Wt. of covered crucible . . . . .	gm.
Wt. of zinc . . . . .	gm.
Wt. of covered crucible and contents after heating	gm.
Wt. of covered crucible . . . . .	gm.
Wt. of contents after heating . . . . .	gm.
Wt. of zinc . . . . .	gm.
Change in weight . . . . .	gm.

Obtain about 3 gm. of zinc dust on a slip of paper creased lengthwise, and slide it into the crucible. Weigh the covered crucible and zinc accurately. Enter the weight in the RECORD.

Place the covered crucible on the triangle supported by a ring on an iron stand as shown in Fig. 9. Heat gently with a low flame for a minute or two, then increase the heat until the flame is just above the middle of the crucible. Heat for about fifteen minutes. Occasionally lift the cover for an instant by grasping the ring firmly with the forceps.

Let the crucible cool. Weigh it. Enter the weight, and complete the RECORD.

Show the completed RECORD to the Teacher before throwing away the contents of the crucible. (NOTE. — The crucible, if blackened, can be cleaned by warming a little dilute hydrochloric acid in it.)

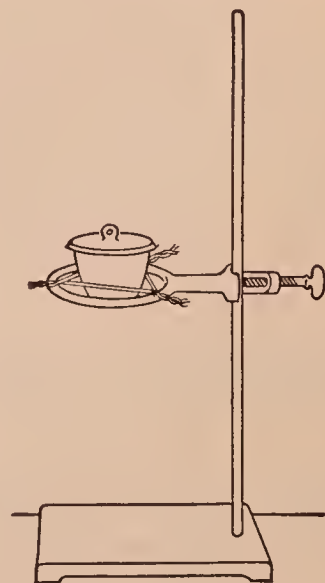

FIG. 9. — Covered crucible on a triangle



## Optional Exercises

1. What is the result of heating a known weight of a metal in air?
2. To what is the difference in weight due?
3. What is the name of the product?
4. Complete:  $\text{Zinc} + \text{---} = \text{---} \text{---}$ .

## SUPPLEMENTARY EXERCISES ON OXYGEN

### Supplementary Exercise 2 — Examples of Chemical Change in Exercise 3

MATERIALS. — Contents of test tube *A* and of the bottles from **Exercise 3, II** (*b*), (*c*); potassium chlorate (pure) and silver nitrate solutions, litmus paper (blue).

APPARATUS. — Funnel, filter paper.

(*a*) Add 15 cc. of water to the test tube (from **Exercise 3, I**), warm gently to loosen the contents and dissolve the soluble material. Filter (ask directions or follow directions in APPENDIX, § 4). (1) To a few cc. of the filtrate (the liquid that went through the filter paper) add a few drops of silver nitrate solution, and observe the result. The solid product is silver chloride, and is always formed when silver nitrate and any chloride (in this case potassium chloride) interact. (2) Now add silver nitrate solution to (pure) potassium chlorate solution, and observe the result. Compare with (1) and note the difference.

(*b*) Heat strongly a part of the black substance left on the filter paper as in **Supplementary Exercise 1**, and test for oxygen. Note if oxygen is given off. Compare the rest of the black substance with a sample of the manganese dioxide used in **Exercise 3** and see if they are apparently the same.

*In your laboratory notes write answers to these questions.*  
(1) *What chemical change took place in **Exercise 3, I**? (2) What is the verbal equation for the change? (3) The chemical equation? (4) From what compound did the oxygen come in **Exercise 3, I**?*

(c) Dip a glass rod into the liquid saved from **Exercise 3, II (b)**, touch a piece of blue litmus paper with the moistened end, and observe the change in color. This change is caused by acids; in this case by sulfurous acid ( $\text{H}_2\text{SO}_3$ ) which was formed by the uniting of sulfur dioxide ( $\text{SO}_2$ ) and water.

(d) Shake the bottle saved from **Exercise 3, II (c)** and note the cloudiness of the liquid. Recall that both liquids at first were clear. The cloudiness is caused by particles of insoluble calcium carbonate suspended in the liquid. The calcium carbonate ( $\text{CaCO}_3$ ) is formed by a reaction between carbon dioxide and limewater, which is a solution of calcium hydroxide ( $\text{Ca}(\text{OH})_2$ ).

*In your laboratory notes write answers to these questions.*

(1) *What is (a) the verbal and (b) the chemical equation for the formation of sulfur dioxide? (2) Of carbon dioxide? (3) Of sulfurous acid? (4) Of calcium carbonate?*

### Optional Exercises

1. What is the test for sulfur dioxide?
2. What is the test for carbon dioxide?
3. How would you distinguish a chloride from a chlorate?
4. Complete: (a)  $\text{SO}_2 + \text{---} = \text{H}_2\text{SO}_3$ ; (b)  $\text{CO}_2 + \text{---} = \text{CaCO}_3$ .
5. State the completed equations in 4 in your own words.

### Supplementary Exercise 3 — Preparation and Properties of Oxygen (Short Method)

**MATERIALS.** — Lead dioxide, potassium chlorate, sodium peroxide, hydrogen peroxide, dilute sulfuric acid, potassium permanganate solution, joss stick.

**APPARATUS.** — Test tube and holder (Fig. 2), burner.

(a) Put a little lead dioxide into a test tube as shown in Figs. 4 and 5. Attach the holder, and heat gently (Fig. 2). After a short time, test for oxygen by putting a glowing joss stick into the tube near (but not touching) the substance. Note the effect on the glowing joss stick.

(b) Proceed as in (a), using potassium chlorate. Note the result.

(c) Fill a test tube nearly full of water and stand it in the test tube rack. Obtain a little sodium peroxide (Care!) on a creased paper, cautiously slip the sodium peroxide into the water, and quickly put a glowing joss stick into the gas in the upper part of the test tube. Note the result.

(d) Fill a test tube half full of fresh hydrogen peroxide, add half the volume of dilute sulfuric acid, shake, and then nearly fill the test tube with potassium permanganate solution. Immediately test the escaping gas with a glowing joss stick. Note the result.

*Write a brief account of this exercise in your laboratory notes, stating a conspicuous property of oxygen.*

#### Supplementary Exercise 4 — Preparation of Copper Oxide by Heating Copper in Air

MATERIAL. — Copper borings.

APPARATUS. — Evaporating dish, test tube fitted with a cork.

Put about 4 gm. of clean copper borings in an evaporating dish and stand the dish on a gauze-covered ring attached to an iron stand (Fig. 10). Heat the dish carefully but intensely about ten minutes. Then heat for five minutes by holding the flame directly upon the contents of the dish. Note the marked change in the copper.

When the dish is cool, transfer the contents to a test tube, cork tightly, and save for **Exercise 10**. (NOTE. — The dish can be cleaned by warming dilute nitric acid in it.)

*Write answers to these questions in your laboratory notes. (1) What is the chemical name and formula of the compound formed?*

*(2) What elements combined? (3) What general name is given to this kind of chemical change? (4) What special name?*

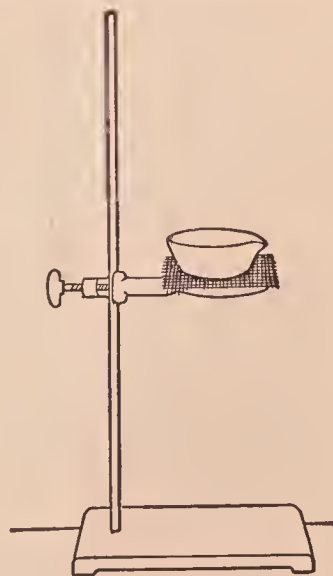

FIG. 10. — Evaporating dish on a gauze-covered ring



## Supplementary Exercise 5 — Slow and Rapid Oxidation — Teacher's Exercise

**MATERIALS.** — Powdered potassium nitrate, charcoal, phosphorus-tipped match, bottle of oxygen, iron filings (free from oil), phosphorus (for *(d)*), magnesium ribbon (for *(e)*), bottle of oxygen (for *(e)*).

**APPARATUS.** — As in Fig. 11, iron pan (or brick).

**Caution.** — See *(d)*. Special care must be taken in all exercises in which phosphorus is used. The substance oxidizes so quickly in the air that it often takes fire unexpectedly. To prevent its oxidation it is kept under water. It is dangerous to handle, since the burns made by it are deep and painful.

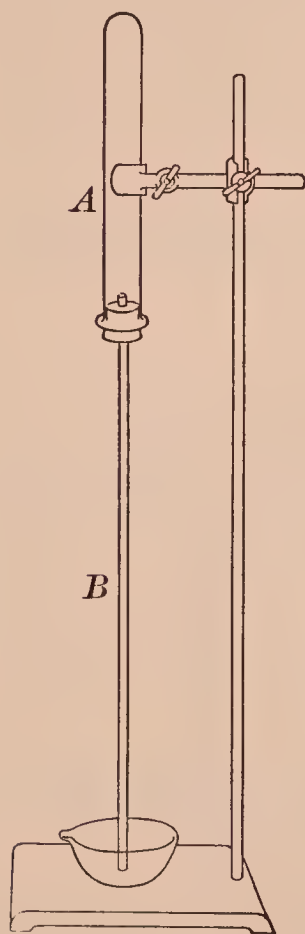

FIG. 11.—Apparatus  
for showing slow  
oxidation

*(a)* Construct an apparatus as shown in Fig. 11. Wet the inside of the test tube *A*, drop in clean iron filings, and roll the test tube to make the filings stick. Insert the stopper with the long tube *B*, invert, and clamp the test tube *A* to the iron stand so that the open end of the tube *B* is just above the bottom of the dish filled with water (Fig. 11). Let the whole apparatus stand undisturbed for an hour or two. Then note the height of the water in the long tube.

*(b)* Lay a piece of charcoal on an iron pan (or brick), heat it with a direct flame, and when hot, cautiously sprinkle powdered potassium nitrate upon the hot surface. As the chemical action begins, continue to sprinkle on the potassium nitrate. Observe the action, especially its violence and rapidity, also the effect on the charcoal.

*(c)* Rub the head of a phosphorus-tipped match with the finger in a dark place, and note the result.

*(d)* See **Caution**. Lift a piece of phosphorus from the bottle with the forceps, put it in an evaporating dish nearly

full of water, cut off a thin slice with a sharp knife, return the rest of the phosphorus to the bottle, and place the slice on an iron pan (or a brick). Stand well back, and observe the result.

(e) Grasp one end of a short piece of magnesium firmly with the forceps, hold the other end in the flame for an instant, then remove it, and let the magnesium burn in the air.

In a similar way light another piece and quickly thrust it into a bottle of oxygen. Compare the results. Note in which case oxidation was more rapid.

*Write in your laboratory notes a brief account of this exercise.*

*Write also answers to these questions. (1) In (a) what caused the water to rise in B? (2) In what parts of this exercise was little heat liberated? Considerable heat? Why? (3) What is the name and the formula of the oxides produced in (b), (c), (d), (e)?*

## CARBON

### ★Exercise 5 — Properties of Charcoal

**MATERIALS.** — Wood charcoal (lump), animal charcoal, test wire, (see Fig. 22 and APPENDIX, § 5 (d)) crucible, vinegar, hydrogen sulfide solution.

**APPARATUS.** — Test tube fitted with a cork, crucible and support.

**A. Wood Charcoal.** — Wind the end of a test wire around a piece of charcoal, hold it in the flame, and observe the result, especially the ease or difficulty of ignition, presence or absence of flame and smoke, formation of ash.

**B. Animal Charcoal.** — (a) Cover the bottom of a crucible with animal charcoal, stand the crucible on a triangle and heat intensely for about half an hour. (Meanwhile do (b), (c).) Examine the residue. Note the color. Compare with a sample of the original charcoal.

(b) Fill a test tube one-fourth full of powdered animal charcoal (refer to Figs. 4, 5). Add 10 cc. of hydrogen sulfide solution, and cork securely. Shake well. After ten minutes, remove the stopper and smell of the contents. Note if the odor is much less offensive. Conclude what property of animal charcoal this exercise illustrates.

(c) Fill a test tube one-fourth full of powdered animal charcoal (refer to Figs. 4, 5), add 10 cc. of vinegar, shake thoroughly, and then warm gently. Filter through a wet paper. Compare the colors of the filtrate and the original vinegar. Conclude what property of animal charcoal this exercise illustrates.

*Write a summary of the properties of charcoal in your laboratory notes.*

### **\*Exercise 6 — Reduction of Copper Oxide by Carbon**

**MATERIALS.** — Powdered copper oxide, powdered wood charcoal, calcium hydroxide solution.

**APPARATUS.** — As in Fig. 12, lens.

Grind together in a mortar about 5 gm. of copper oxide and 1 gm. of powdered wood charcoal. Put the mixture on a creased paper (refer to Figs. 4, 5) and slip it into the test tube *A*. Fill the bottle *B* half full of calcium hydroxide solution. Arrange the apparatus as in Fig. 12.

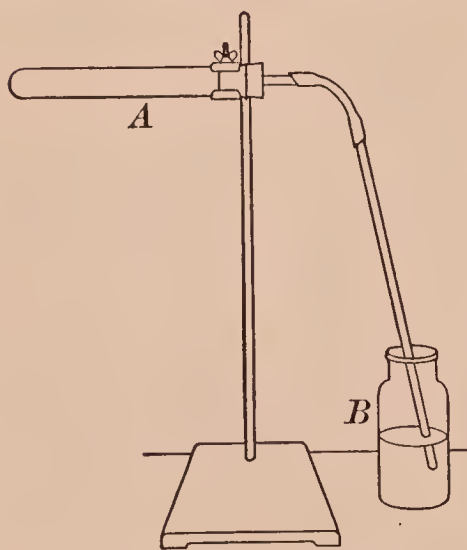

FIG. 12. — Apparatus for reducing copper oxide with carbon

Heat the test tube gently at first, and adjust the height so the gas will bubble through the calcium hydroxide in *B*. Heat intensely for about ten minutes, moving the burner along the part of the test tube that contains the mixture. Observe the change in the calcium hydroxide.

As soon as a definite change is noted in *B*, remove the end of the delivery tube from *B*, and stop heating. Let the test tube cool and pour the contents into a mortar. Examine carefully with the eye and with a lens. Note another substance besides carbon.

*Write in your laboratory notes an interpretation of the chemical change in *A* and in *B*, in (a) words and (b) chemical equations.*



## ★Exercise 7—Preparation and Properties of Carbon Dioxide

**MATERIALS.** — Calcium carbonate, dilute hydrochloric acid, candle fastened to a wire, joss stick, calcium hydroxide solution.

**APPARATUS.** — As in Fig. 13. *A* is a 250 cc. bottle provided with a two-hole stopper, through which passes the dropping tube *B* and the right-angle bend *C*; the tube *D* (15 cm. or 6 in.) is attached to the bent tube by the rubber tube *E*.

Instead of the apparatus shown in Fig. 13, one of the simple forms shown in Fig. 14 may be used; in these the lower end of the thistle tube must be beneath the acid.

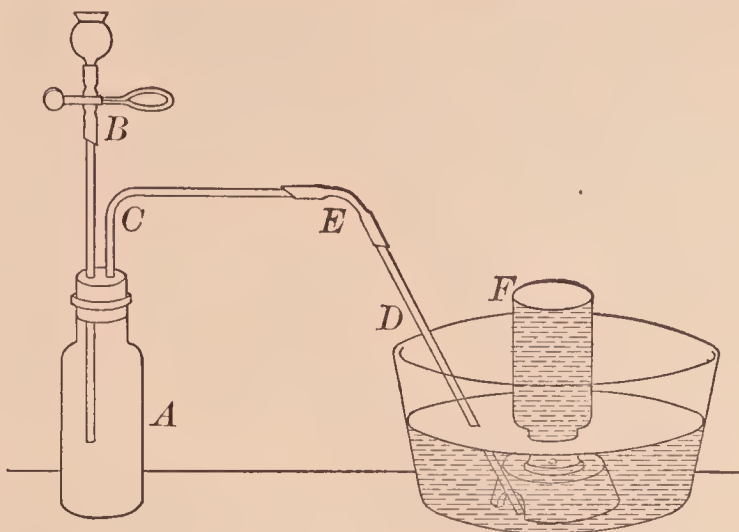

FIG. 13. — Apparatus for preparing carbon dioxide

The dropping tube is made as follows: Cut off the top of a thistle tube about 2.5 cm. (1 in.) below the juncture of the stem and cup, and heat the sharp ends a minute or two in the flame; when cool, slip a *thick-walled* rubber tube (5 cm. or 2 in. long) over one end of the stem, attach a pinch-clamp to the rubber tube, and connect the tube with the cup, taking care to have the ends of the glass tubes as close together as possible. If properly constructed, the cup will remain upright when full of liquid.

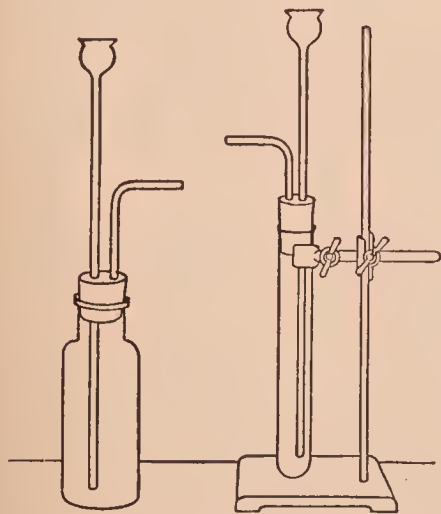

FIG. 14. — Simple apparatus for preparing carbon dioxide

as in Fig. 13. Fill the pneumatic trough with water, fill a bottle with water, cover with filter paper (Fig. 7), invert, stand it on the support, and remove the paper. Fill three other bottles and have them ready.

Introduce enough dilute hydrochloric acid through the dropping tube *B* to cover the calcium carbonate. Carbon dioxide will be evolved at once. Collect four bottles, cover tightly with filter paper, and stand aside till needed. Proceed at once with **II**.

**II. Properties.** — (a) Plunge a blazing joss stick into a bottle. Observe the effect on both gas and joss stick.

(b) Lower a short, lighted candle into a bottle of air, and quickly invert a bottle of carbon dioxide over it, holding the bottles mouth to mouth. Observe the effect on the candle.

(c) Pour a little calcium hydroxide solution into a bottle of carbon dioxide, cover with the hand, and shake vigorously. Note the effect on the calcium hydroxide. This is the usual test for carbon dioxide.

(d) Invert a bottle of carbon dioxide in the pneumatic trough, and shake vigorously, keeping the mouth beneath the water. Observe the result (inside the bottle).

NOTE. — As soon as (d) is performed wash the acid from the marble and save the solid for other exercises.

*Write a brief account of I in your laboratory notes.*

*Write also answers to these questions. (1) What do II (a) and (b) show about the relation of carbon dioxide to combustion? (2) What does II (b) show about the relative weights of carbon dioxide and air? (3) What does II (d) show about the solubility of carbon dioxide?*

*Write also a statement of the test for carbon dioxide, including the (a) verbal equation and (b) chemical equation.*

### **Exercise 8 — Carbon Monoxide — Teacher's Exercise**

MATERIALS. — Oxalic acid, calcium hydroxide solution.

APPARATUS. — As in Fig. 15.

**Caution.** — Carbon monoxide and oxalic acid are poisonous. Hot sulfuric acid is dangerous. Perform this exercise in the hood with unusual care.

**I. Preparation.** — Put 10 gm. of oxalic acid in the flask *A* (Fig. 15), and add 25 cc. of concentrated sulfuric acid. Put

enough calcium hydroxide solution in *B* to cover the end of the tube *E*. Arrange the apparatus as in Fig. 15.

Heat the flask *A* gently, and carbon monoxide will be evolved. Collect all the gas, but do not use the first bottle, covering the bottles with glass plates as they are filled, and setting them aside temporarily. When the last bottle has been collected and covered, loosen the stopper in *B*, and remove the end of *H* from the water in the trough.

Proceed at once with II.

**II. Properties.** — (a) Note that the gas is colorless.

(b) Hold a lighted match at the mouth of a bottle. Note the flame, especially its color. After the flame has disappeared, drop

a lighted match into the bottle. Note the result. Draw a conclusion and verify it by (c).

(c) Burn another bottle of gas, note the flame again, and after the flame has disappeared, pour calcium hydroxide solution into the bottle and shake. Note the result.

*Write in your laboratory notes (1) a brief description of the preparation of carbon monoxide and (2) a summary of the observed properties of carbon monoxide.*

*Write also answers to these questions. (3) What gas besides carbon monoxide was produced in I? (4) What are the equations for I, II (b) and (c)?*

### Optional Exercises

1. How could carbon monoxide be detected in (a) the smoke from a fire, and (b) the exhaust gases from an automobile?

2. Complete: (a)  $C + CO_2 = \text{---}$ ; (b)  $CO + O_2 = \text{---}$ .

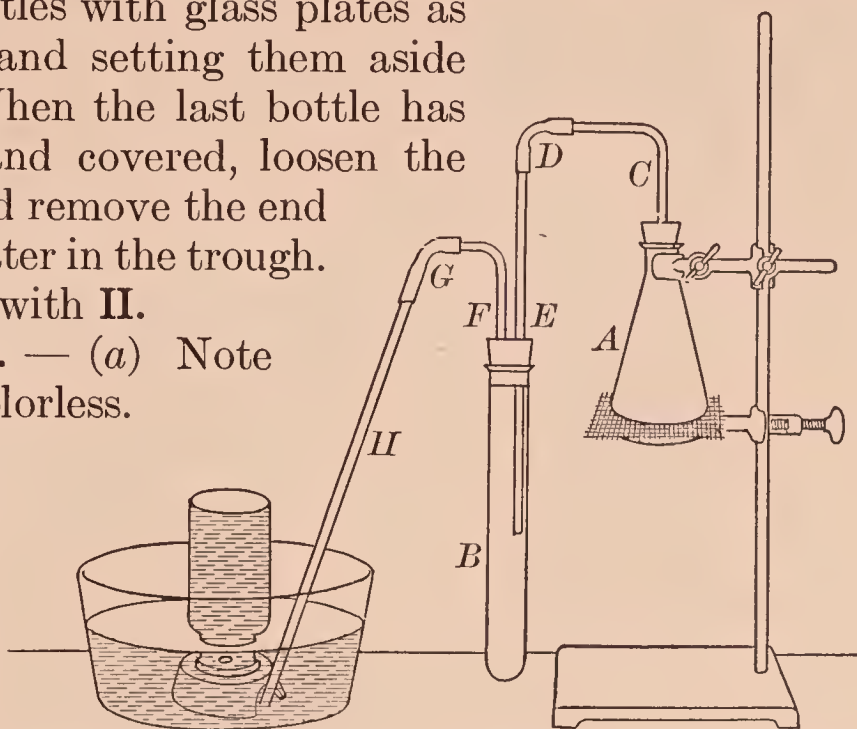

FIG. 15. — Apparatus for preparing carbon monoxide



# SUPPLEMENTARY EXERCISES ON CARBON DIOXIDE

## Supplementary Exercise 6 — Combustion and Carbon Dioxide

**MATERIALS.** — Copper wire, charcoal, limewater, candle, wood, paper, denatured alcohol, gasolene.

**APPARATUS.** — Bent tube as in Fig. 17 for (g).

(a) Wind one end of a copper wire around a small lump of charcoal, hold it in the flame until the edges glow, and then lower it into a bottle. Let it remain for a minute or two, then remove. Fill the bottle one-fourth full of fresh limewater, cover with the hand, and shake. Observe the result. Conclude to what the result is due.

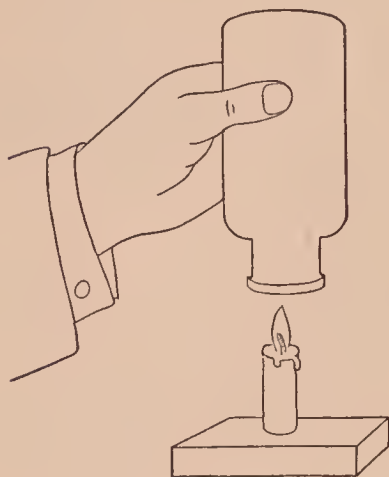

FIG. 16. — Collecting one product of a burning candle

(b) Light a candle and stick it to a block of wood with a drop of melted candle wax. Hold a cold, dry bottle over the lighted candle (Fig. 16). Remove the bottle in a moment, invert, pour in some clear limewater, and shake.

Note the change. Conclude what caused the change.

(c) Burn wood (*e.g.* a match) and paper in separate bottles and test as in (a). Note each result.

(d) Put several drops of denatured alcohol in an evaporating dish, set it on fire, and hold a bottle over the flame. Test as in (a). Note the result. (NOTE. — If the result is not marked, burn a little alcohol in the bottle and then test.)

(e) Proceed as in (d), using gasolene (CARE!) instead of alcohol. Note the result. (See NOTE in (d).)

(f) Hold a bottle over a low Bunsen flame for a minute or so, and then test as in (a). Note the result.

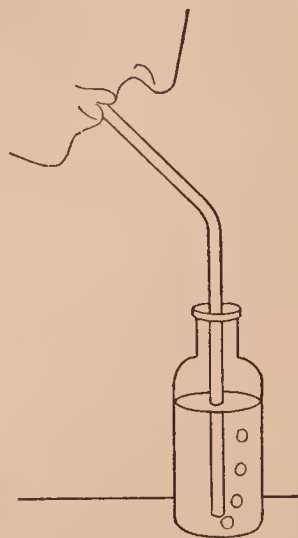

FIG. 17. — Testing the breath for carbon dioxide

(g) Exhale the breath through a glass tube into a bottle half full of limewater (Fig. 17). Describe the result. Conclude what gas the breath contains.

*Write briefly the results of this exercise in your laboratory notes.*

*Write also answers to these questions. (1) Is carbon dioxide a product of combustion in each case? (2) What are two tests for carbon in a compound?*

### Supplementary Exercise 7 — A Fire Extinguisher and Carbon Dioxide — Teacher's Exercise

MATERIALS. — Dilute sulfuric acid, saturated sodium bicarbonate solution.

APPARATUS. — Bottle with one-hole stopper and tubes as in Fig. 18.

Make a simple extinguisher like that shown in Fig. 18. The bottle and tubes are those used (as *A-C-E-D*) in the apparatus shown in Fig. 13. The bottle is filled about two-thirds full with saturated sodium bicarbonate solution. The small tube (inside the bottle) contains dilute sulfuric acid and a piece of lead to hold it down after it is lowered into the solution. Connect the tubes with the stopper and push the stopper well down into the neck of the bottle.

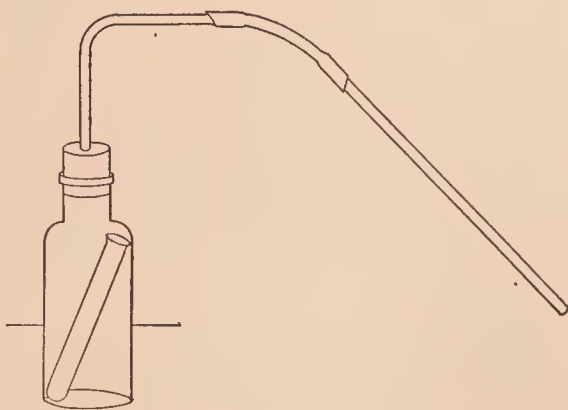

FIG. 18. — Simple fire extinguisher

Build a small fire in a dish or on some bricks. Hold the end of the tube in one hand, with the other grasp the bottle by the neck, taking care to hold the stopper tightly with the fingers, invert the bottle, and direct the stream upon the fire.

*Write answers to these questions in your laboratory notes.*

(1) *Why are sulfuric acid and sodium bicarbonate used in a fire extinguisher? (2) Why does the liquid flow out of a fire extinguisher with such force?*



# HYDROGEN

## ★Exercise 9 — Preparation and Properties of Hydrogen

**MATERIALS.** — 10 gm. of granulated zinc, dilute sulfuric acid, copper sulfate solution, wax taper.

**APPARATUS.** — As in Fig. 19. See also Fig. 20 for optional forms.

**I. Preparation.** — Slip the zinc into the bottle (or test tube) — Fig. 19. Insert the stopper with its tubes. If one of the optional forms (Fig. 20) is used, the thistle tube must dip beneath the surface of the acid. Be sure there are no leaks. Fill the pneumatic trough with water as usual, and adjust the apparatus so that the end of the delivery tube rests on the bottom of the trough under the hole in the support. Fill the bottles with water, and cover each with

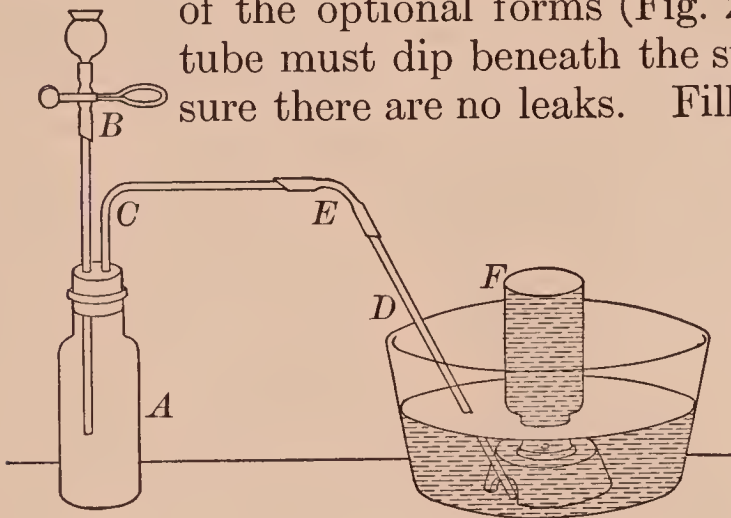

FIG. 19. — Apparatus for preparing hydrogen

the filter paper; invert one in the trough, remove the paper, and stand the inverted bottle upon the support (see Fig. 19).

Put 2 or 3 cc. of copper sulfate solution in the cup, fill with dilute sulfuric acid, and let the acid mixture run into the bottle by pinching the clamp; if the acid does not flow freely down the tube into the bottle, loosen the stopper *for an instant*. (The copper sulfate hastens the chemical change.) The gas will bubble through the water up into the bottle.

Collect and remove four bottles of gas as in the **Preparation of Oxygen (Exercise 3)**, taking care to cover each bottle tightly with a piece of wet filter paper. If the evolution of gas slackens

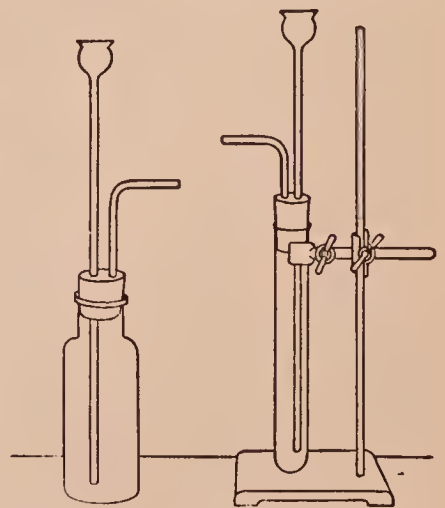

FIG. 20. — Optional apparatus for hydrogen

or ceases, add a little more acid through the dropping tube.

Save the contents of the generator bottle (or test tube) for **Supplementary Exercise 9**. Perform **II** at once.

**II. Properties.** — (a) Uncover a bottle for an instant to let a little air in, and then hold a lighted match at the mouth of the bottle. Observe the result.

(b) Remove the paper from another bottle and allow it to remain uncovered for three minutes — by the clock. Then show the presence or absence of hydrogen by holding a lighted match at the mouth of the bottle. Observe the result.

(c) Stand a covered bottle of hydrogen on the desk, place a bottle of air over it, remove the paper, and bring the mouths of the bottles together. Let them remain in this position for a minute or two, then remove the upper bottle and cover both with wet filter paper.

Remove the paper from one bottle and hold a lighted match at the mouth. Observe the result. Do the same with the other bottle.

(d) (Read directions carefully.) Invert a covered bottle of hydrogen, remove the paper, and quickly thrust a lighted taper up into the bottle. Withdraw the taper slowly. Then insert and withdraw it several times, and observe carefully (1) if the hydrogen burns, (2) if so, where, and (3) if the taper burns both inside and outside the bottle. Feel of the neck of the bottle and note the result.

NOTE. — As soon as **II** is completed, wash the zinc thoroughly with water several times, and save it for other exercises.

*In your laboratory notes write (1) a very brief account of **Exercise 9, I** and (2) brief statements of the observations made in **II**.*

### Optional Exercises

1. What property of hydrogen is shown by **II (b)**? By **II (c)**?
2. As in 1, what properties by **II (d)**?

3. State the conspicuous physical properties of hydrogen.
4. What is a test for hydrogen?
5. Why was there a marked explosion in (a)? Why none in (d)?
6. Does hydrogen support combustion? Compare with oxygen.
7. Sketch (from memory, if possible) the apparatus used to prepare hydrogen.

### ★Exercise 10 — Reduction of Copper Oxide by Illuminating Gas

**MATERIALS.** — 5 gm. of copper oxide (or the copper oxide saved from **Supplementary Exercise 4**).

**APPARATUS.** — As in Fig. 21.

Arrange the apparatus as in Fig. 21. *A* is a large test tube. *B* is a piece of rubber (burner) tubing tightly connected with a piece of glass tubing which passes through a one-hole stopper. Clamp the stopper to the stand so that the

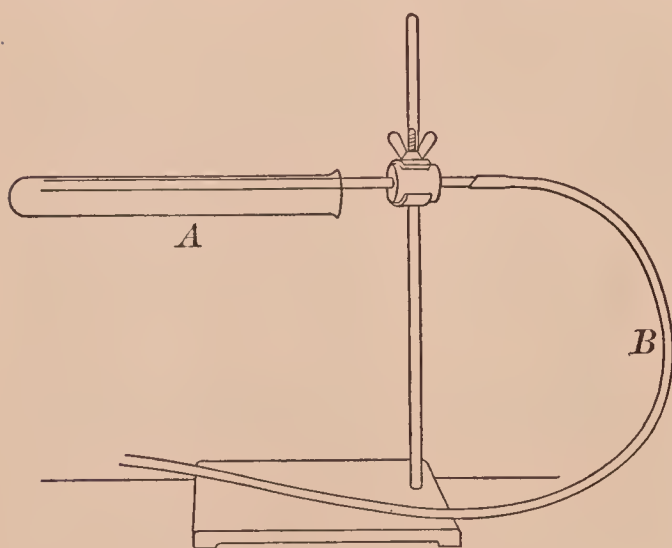

FIG. 21. — Apparatus for reducing copper oxide by illuminating gas

free end of the glass tube is slightly raised. Connect the free end of the rubber tube to the illuminating gas supply.

Turn on the gas, light it at the end of the glass tube, and regulate the flame so that it is about 2 cm. (nearly 1 in.) long.

Put the copper oxide in the test tube *A*, hold it horizontal and tap it

to spread out the solid. Then pinch the tube to extinguish the gas, and slip the test tube over the glass tube as shown in the figure. Light the gas at the mouth of the test tube and let it burn.

Heat gently the end of the test tube containing the copper oxide. Observe (1) the change in the solid and (2) the deposit



on the cooler part of the test tube. Pinch the rubber tube and turn off the gas.

*Write answers to these questions in your laboratory notes.*  
(1) *In what way was the solid changed (a) physically and (b) chemically?* (2) *What was the deposit in the cooler part of the tube?* (3) *How would you explain its formation (knowing that illuminating gas contains hydrogen)?* (4) *What is (a) the verbal and (b) the chemical equation for the reaction in A?*

### **★Exercise 11 — Reaction between Sodium and Water — Teacher's Exercise**

**MATERIALS.** — Sodium, zinc sulfate solution, tea lead or wire gauze, litmus paper.

**APPARATUS.** — Test wire, test tube clamped over dish as in Fig. 23.

**Caution.** — Sodium is a dangerous substance. It should be handled cautiously and used strictly according to directions. Small fragments obtained for exercises should be protected from water by a mortar or dish. If any sodium is left from an exercise, it must not be thrown into the refuse jar, but returned to the bottle containing kerosene which protects the sodium.

(a) With dry forceps remove a lump of sodium from the bottle, soak up the oil with filter paper, cut off three or four small pieces and put the lump back into the bottle; place a mortar over the pieces of sodium until needed.

Fill an evaporating dish half full of water. Drop a piece of sodium upon the water in the dish, stand back and observe the result, waiting for the slight explosion before approaching the dish again. Repeat with the rest of the sodium, piece by piece.

When the chemical action is over, stand the dish on a gauze-covered ring attached to an iron stand, and heat until the water is entirely evaporated. Meanwhile proceed with (b).

When the water has evaporated, note the white residue. Test it in three ways.

(1) Moisten the end of a glass rod, touch the residue with it, and then draw this end across a piece of moistened red litmus paper. Observe the change in color of the litmus; this change is caused by hydroxides — sodium hydroxide in this case.

(2) Moisten the looped end of a clean test wire (Fig. 22), touch the residue with it, and hold the end of the wire in the

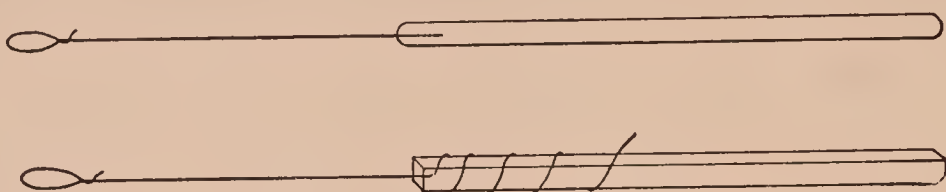

FIG. 22. — Test wires — platinum (upper), nichrome (lower)

flame. Observe the color of the flame; it is caused by sodium. The production of this color is a *test for sodium*.

(3) Dissolve the rest of the residue in 10 cc. of water, pour a little of the solution into a test tube, add a few drops of zinc sulfate solution, and shake. Observe the result. Now pour the rest of the solution into the test tube and shake well. Observe the result. These two results serve as a test for the hydroxide part of sodium hydroxide.

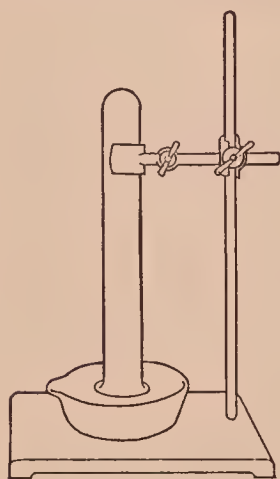

FIG. 23. — Apparatus for studying the reaction between water and sodium

(b) Cut off five or six pieces of sodium and protect them as in (a).

Fill an evaporating dish two-thirds full of water. Fill a test tube full of water, cover and invert it, and clamp it as shown in Fig. 23. Make several holes in a piece of tea lead (about 5 cm. or 2 in. square), wrap a small piece of clean sodium loosely in the *dry* tea lead, and slip it under the test tube. (Wire gauze may be used instead of tea lead.) A gas will rise in the test tube.

Proceed similarly with additional pieces of sodium and *dry* tea lead until the test tube is full of gas. Then unclamp it, keep it mouth downward, and hold a lighted match at the mouth. Observe the result immediately, especially at the mouth of the tube.



*Write in your laboratory notes answers to these questions.*  
(1) *What is the name of each substance formed in the reaction between water and sodium?* (2) *What is (a) the verbal and (b) the chemical equation for the reaction?*

### Optional Exercises

1. State the test for (a) sodium and (b) an hydroxide.
2. Consult a textbook for the interpretation of the reactions in (a) (3), and write the equations.

## SUPPLEMENTARY EXERCISES ON HYDROGEN

### Supplementary Exercise 8 — Preparation of Hydrogen — Short Methods

**MATERIALS.** — Zinc, magnesium, aluminum, iron, dilute hydrochloric acid, dilute sulfuric acid, sodium hydroxide.

(a) Fill a test tube half full of dilute hydrochloric acid, stand it in the rack, and drop in a small piece of zinc. Hold a lighted match at the mouth of the test tube and observe the result. (If the test is not decisive, add more zinc, warm gently, or wait until more gas accumulates in the test tube.)

Proceed in the same way with magnesium and iron (in the form of filings); use separate test tubes, and heat, if the action is slow. Observe the result in each case.

(b) Proceed as in (a), using dilute sulfuric acid. Observe the result in each case.

(c) Roll two or three small, thin pieces of aluminum into a ball, drop it into a test tube, slip in a piece of sodium hydroxide about 2.5 cm. (or 1 in.) long, and add a little water. Warm gently. Test as in (a) and observe the result.

*Write in your laboratory notes answers to these questions.*  
(1) *What is the source of the hydrogen in each experiment?*  
(2) *What is the verbal equation for the chemical change in each case (except (c))?* (3) *What is the chemical equation for zinc and each acid?*

## Supplementary Exercise 9 — The Reaction between Zinc and Sulfuric Acid — Teacher's Exercise

**MATERIALS.** — Contents of the hydrogen generator from **Exercise 9**, sodium hydroxide and barium chloride solutions.

**APPARATUS.** — Evaporating dish, iron stand, etc. (Fig. 24).

If the generator contains a solid (besides the zinc), add a little warm water to dissolve it. Then filter (see **APPENDIX**, § 4) into an evaporating dish and concentrate the solution

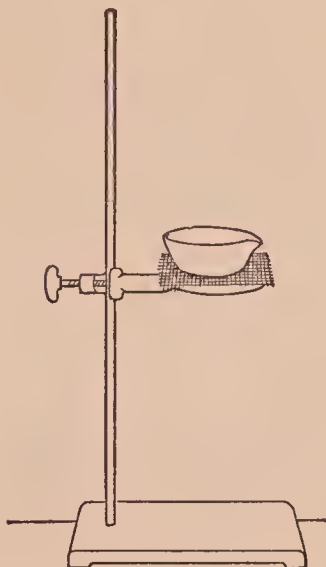

FIG. 24. — Apparatus for concentrating a solution

(1) by letting the dish remain undisturbed so that most of the water will evaporate or (2) by heating the dish on a gauze-covered ring which is attached to an iron stand as in Fig. 24. Heat until the volume of the liquid is reduced about one-half, and set the dish aside to cool. Crystals will separate from the solution.

(a) Remove the crystals and dry with filter paper. Note the color, luster, and general shape.

Wash some quickly in cold water, dissolve the clean crystals in about 20 cc. of water, and divide the solution into two parts.

(b) Test one part for a sulfate by adding barium chloride solution. Note the precipitate, especially the color and the fineness. It is barium sulfate, and is formed by the reaction between a sulfate and a dissolved barium compound. Its formation is a *test for a sulfate*.

(c) Test the other part for zinc. (1) Add sodium hydroxide solution slowly with constant shaking until no more precipitate (zinc hydroxide) is formed, and note the color and texture; then (2) add considerable sodium hydroxide solution, shake well, and note the final result. The precipitate of zinc hydroxide formed at first is changed by the excess of sodium hydroxide into soluble sodium zincate; the behavior of zinc compounds with sodium hydroxide is a *test for zinc*.

*Write answers to these questions in your laboratory notes.*

(1) *What substance besides hydrogen is formed by the reaction*

between zinc and sulfuric acid? (2) What is (a) the verbal equation and (b) the chemical equation for the reaction?

### Optional Exercises

1. State in your own words the test for a sulfate.
2. As in 1, for zinc.

### Supplementary Exercise 10 — Reduction of Copper Oxide by Hydrogen — Teacher's Exercise

MATERIALS. — 5 gm. of copper oxide, 10 gm. of granulated zinc, dilute sulfuric acid, copper sulfate solution.

APPARATUS. — As in Fig. 25. The parts lettered *A*, *B*, *C*, *D*, *E* constitute the hydrogen generator used in Exercise 9. *F* is a large test tube fitted with a two-hole stopper; the delivery tube *E* passes through one hole and extends nearly to the bottom of the test tube. The right-angle tube *G* passes just through the other hole; the tube *G* is lengthened by the rubber tube *H*.

Arrange the apparatus as in Fig. 25. Slip the copper oxide into the *dry* test tube *F* (Fig. 25), hold the tube in a horizontal position and tap it gently to spread the solid into a thin layer. Connect this test tube with the rest of the apparatus, and clamp it into the proper position, taking care not to crush the tube. Put the zinc into the bottle *A*.

Pour about 2 cc. of copper sulfate solution into the cup, fill the cup nearly full with dilute sulfuric acid, pinch the run into the generator bubble freely, let more little acid in the cup.

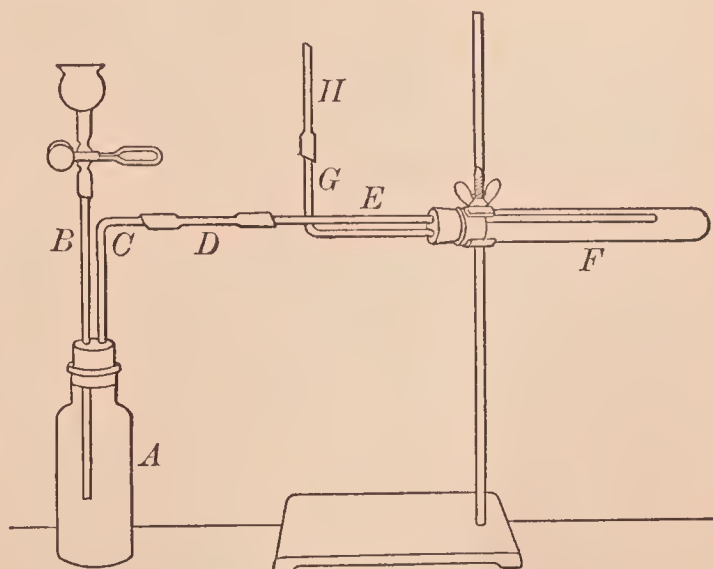

FIG. 25. — Apparatus for reducing copper oxide by hydrogen

clamp, and let about half the acid run into the generator. If the hydrogen does not bubble freely, let more acid run in, taking care to keep a little acid in the cup. Add enough acid to keep the gas



flowing steadily through the apparatus for at least two minutes before lighting the Bunsen burner.

Heat gently the lower part of the test tube where the copper oxide is located. *Do not let the flame come near the rubber tube H.* The gas must flow slowly through the apparatus during the heating; if it does not (as you can tell by the bubbles in the bottle or by smelling the gas at the end of the rubber exit tube), introduce more acid. If the test tube *F* should break, pinch the rubber tube *D* an instant to cut off the flow of hydrogen, and then extinguish the Bunsen burner flame.

Continue to heat until a marked and permanent change is observed inside the test tube *F*. Then stop heating, and extinguish the Bunsen burner flame *at once*. Note the two products in the test tube (disregarding any unchanged copper oxide).

*Write in your laboratory notes answers to these questions.* (1) *What is the name of each product in F?* (2) *What compound was reduced by hydrogen?* (3) *What is (a) the verbal and (b) the chemical equation for the reaction in F?*

### Optional Exercises

1. Describe briefly the whole experiment.
2. Summarize in a few words how **Supplementary Exercise 10** illustrates reduction.
3. How does reduction differ from oxidation?
4. If copper is heated in air and the solid product then heated in hydrogen, (a) what is oxidized, (b) what is reduced, (c) what oxidizes, and (d) what reduces?

## WATER

### Exercise 12 — Purifying Water by Distillation

**MATERIALS.** — Copper sulfate and barium chloride solutions, ammonium hydroxide.

**APPARATUS.** — As in Fig. 26. *A* and *B* are large test tubes, and *C* is a 250 cc. bottle.

Put about 15 cc. of water in the test tube *A*, add 2 or 3 cc. of copper sulfate solution (to color the water), and slip in



two short pieces of glass tubing (to prevent "bumping"). Arrange the apparatus as in Fig. 26; *B* is empty and *C* should be about three-fourths full of cold water.

Heat the water in the test tube *A* to boiling. The steam passes into the test tube *B* and is condensed by the cold water in the bottle *C*. Continue to heat until about 10 cc. has collected. Compare the color of the distillate in *B* with the copper sulfate solution in *A*.

Make two tests of the distillate.

(1) Test half of the distillate for copper by adding ammonium hydroxide. If a copper compound is present, the solution will become deep blue. Note the result.

(2) Test the rest of the distillate for a sulfate by adding barium chloride solution; if a sulfate is present, a fine white precipitate of barium sulfate will be formed. Note the result.

*Write in your laboratory notes a brief description of the exercise and the result of each test of the distillate.*

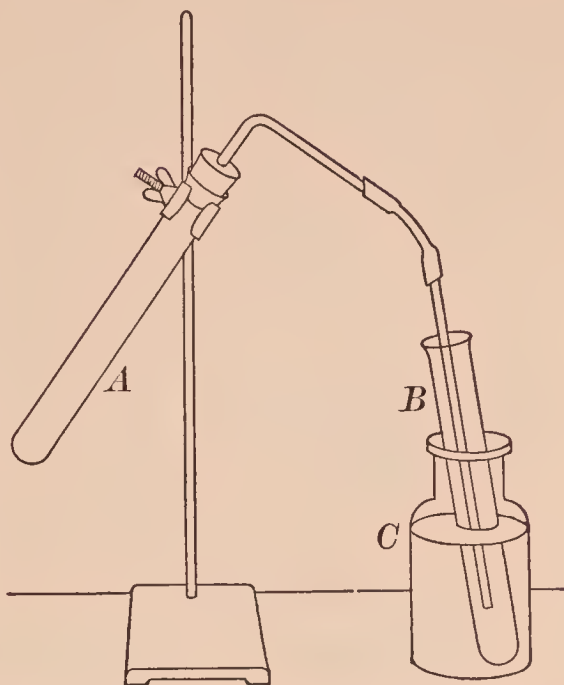

FIG. 26. — Apparatus for distilling water

### ★Exercise 13 — Suspension and Solution of Solids in Water

**MATERIALS.** — Fine clay, calcium sulfate, sodium chloride, potassium permanganate, sodium hydroxide (solid), chalk (powder).

Put about 1 gm. of the powdered substances in separate test tubes (use only a few crystals of potassium permanganate), add 10 cc. of water, and shake well. Note the evidence of suspension or solution. In case of doubt, shake again. If there is still some solid, let it settle, filter half of the clear liquid into an evaporating dish and evaporate the

filtrate by heating the dish on a gauze. Note any definite and conspicuous evidence of solubility.

*Copy the table, given below, in your laboratory notes and insert each result, using the terms suspension and solution.*

SOLUTION AND SUSPENSION OF SOLIDS IN WATER

SOLVENT — 10 CC.	SOLID — 1 GM.	RESULT
Water at temperature of Laboratory	1. Clay	1.
	2. Calcium Sulfate	2.
	3. Sodium Chloride	3.
	4. Potas. Permanganate	4.
	5. Sodium Hydroxide	5.
	6. Chalk	6.

**★Exercise 14 — Effect of Heat on the Solubility of Solids in Water**

MATERIALS. — About 5 gm. each of powdered copper sulfate and potassium chlorate, calcium hydroxide solution for (c).

(a) Label two test tubes, I, II. Put 10 cc. of water into each. To I add 1 gm. of powdered copper sulfate, and to II add 1 gm. of powdered potassium chlorate. Shake each test tube, and then allow them to stand undisturbed until the solid settles. Note the evidence of solubility in each case. (Save for (b).)

(b) Heat I, and add gradually 2 gm. of powdered copper sulfate. Note whether it all dissolves. Heat II and add 2 gm. of powdered potassium chlorate. Note whether it all dissolves. Add the rest of each solid to the respective tubes, and heat (but do not boil). Note the effect of increased heat on the solubility of the solid. Save for **Exercise 15**.

(c) Fill a test tube half full of clear calcium hydroxide solution, and heat it to boiling. Observe the result. Compare with the cold solution. Note the effect of increased heat on the solubility of calcium hydroxide. Note how the result differs from (b).

*Write a brief account of this exercise in your laboratory notes.*

## Exercise 15 — Formation of Crystals

**MATERIALS.** — Solutions from **Exercise 14**, thread or string.

**APPARATUS.** — 2 evaporating dishes or small beakers.

If the contents of the test tubes is not liquid, add a little water, heat gently until the solid dissolves, and pour the hot solution into separate dishes (or beakers). Suspend a piece of thread or string in each solution, and let the solute crystallize (Fig. 27). Remove the thread when crystals have formed on it. Examine a well-shaped crystal.

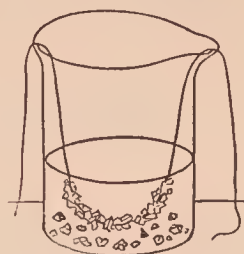

FIG. 27. — Crystallizing

*Write a brief account of this exercise in your laboratory notes.*

## ★Exercise 16 — Effect of Shape on the Solubility of a Solid — Teacher's Exercise

**MATERIAL.** — Crystallized alum.

**APPARATUS.** — 2 large test tubes fitted with corks.

Weigh about 2 gm. of crystallized alum (in one lump, if possible) on the scales, and counterpoise it with a second quantity of equal weight. Pulverize the latter in a mortar. Put each in a test tube, add 25 cc. of water, and insert the cork. Note the time. Shake the tubes gently until the powder has dissolved. Note the time again. Estimate the amount of alum left in the other tube, or, if time permits, continue to shake it at intervals until the solid has dissolved, and note the time again.

Compare the time required to dissolve the powder and the crystal.

*Write a brief account of this exercise in your laboratory notes.*

## ★Exercise 17 — Testing Crystals for Water of Hydration

**MATERIALS.** — Sodium carbonate, potassium dichromate, ferrous sulfate, borax, barium chloride, zinc sulfate, sodium sulfate, calcium sulfate, sodium chloride, potassium nitrate, sugar, magnesium sulfate, potassium bromide.

Test several of the substances for water of hydration by heating gently a dry specimen in a dry test tube inclined so



that the open end is the lower. Observe in each case the change in appearance of the solid during the heating, relative amount of water liberated (if appreciable), and appearance of the residue.

*Write an account of this exercise in tabular form in your laboratory notes.*

**★Exercise 18 — Per Cent of Water of Hydration in a Crystallized Compound**

**MATERIAL.** — Crystallized copper sulfate (powdered) for **A** and crystallized barium chloride for **B**.

**APPARATUS.** — Scales and evaporating dish for **A**, balance and covered porcelain crucible for **B**. (Fig. 28.)

**OBJECT.** — To find the weight of water lost by heating a weighed amount of crystallized copper sulfate, and to calculate the per cent of water of hydration.

**A. First Method.** Copy the form of **RECORD**, as given below, in the notebook, and enter all weights as soon as the weighing is completed.

Clean and dry an evaporating dish and weigh it to a decigram on the scales. Put about 10 gm. of powdered copper sulfate in the dish and weigh to a decigram. Enter the weight at once.

**RECORD**

Weight of dish and copper sulfate before heating . . . . .	gm.
Weight of dish . . . . .	gm.
(a) Weight of copper sulfate . . . . .	gm.
Weight of dish and contents before heating . . . . .	gm.
Weight of dish and contents after heating . . . . .	gm.
(b) Weight of water of hydration . . . . .	gm.
Per cent of water of hydration . . . . .	per cent

Stand the dish with its contents on a gauze-covered ring attached to an iron stand, heat gently for five or ten minutes, and then intensely until the substance becomes a gray powder.



Do not touch the substance, and take special pains not to lose any. Cool slowly and weigh as before. Enter the weight at once.

Complete the entries in the RECORD. Calculate the per cent of water of hydration (*i.e.* divide (b) by (a)). Submit the result to the Teacher before throwing away the contents of the dish.

**B. Second Method.** Prepare a form of RECORD similar to that in A, and enter the weighings as soon as made.

Weigh accurately on the balance a clean, dry porcelain crucible. Put about 2 gm. of crystallized barium chloride in the crucible, and weigh accurately. Support the crucible on a triangle as in Fig. 28, and put on the cover. Heat gently at first, and then strongly for about fifteen minutes. Let the crucible cool, and then weigh it (uncovered).

Calculate the per cent of water of hydration. Submit the result to the Teacher before throwing away the contents of the crucible.

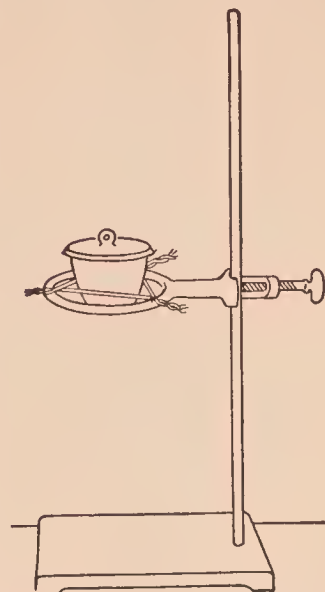

FIG. 28. — Covered crucible arranged for finding the water of hydration in a crystallized compound

### Optional Exercises

1. Compare your result with (1) the correct per cent and (2) the class average.
2. Suggest a source of error in this exercise and how it can be corrected.

### Exercise 19 — Electrolysis of Water (Acid Solution) — Teacher's Exercise

MATERIALS. — Sulfuric acid, joss stick, taper.

APPARATUS. — Hofmann apparatus, source of electric current.

Fill the Hofmann apparatus (Fig. 29) with water containing 10 per cent of sulfuric acid. The water in the reservoir tube should stand a short distance above the tip of the gas tubes after the stopcock in each has been closed. (Water

does not conduct electricity. The acid makes a conducting solution. At the end of the exercise the solution contains the same amount of acid as at the beginning.)

Connect the platinum terminal wires with a battery of at least three cells (or a direct current reduced by suitable resistance). As the action proceeds, small bubbles of gas rise and collect at the top of each tube. Allow the current to run until the smaller volume of gas is 8 to 10 cc.

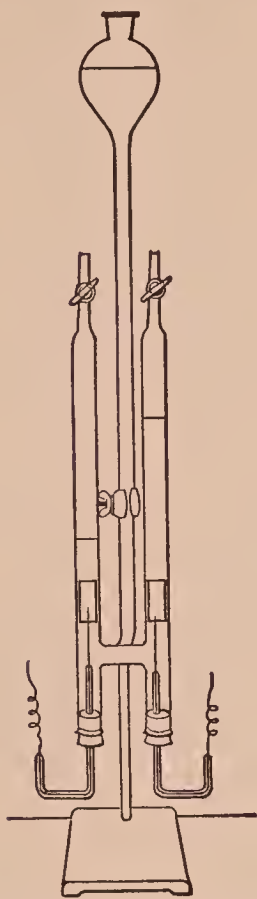

FIG. 29. — Hofmann apparatus for electrolysis

Measure the height of each gas column. Assuming that the tubes have the same diameter, the volumes are in approximately the same ratio as their heights. Note how the volumes compare.

Test the gas as follows: (a) Open the stopcock of the tube containing the smaller quantity of gas long enough to allow the water (or air) to run out of the glass tip, and then close it immediately. Light the joss stick and make the end glow. Then let out a little gas upon a glowing joss stick, and observe the result. Close the stopcock as soon as the result is observed. Repeat, if gas is available.

(b) Open the other stopcock long enough to force out the water (or air) in the glass tip and then close it. Open the stopcock again, let out a little gas slowly, hold a lighted match for an instant at the end of the tip, and immediately thrust a taper into the small and almost colorless flame. Watch for a change in the taper. Close the stopcock as soon as the change is seen. Repeat, if gas is available.

*Write in your laboratory notes answers to these questions.*  
(1) *What gas was found in (a) and in (b)?* (2) *Which gas has (a) the larger and (b) the smaller volume?* (3) *How do the volumes compare?*

## Optional Exercises

1. Describe this exercise.
2. What does this exercise show about the composition of water?
3. What does this exercise show about the relation between electrical and chemical energy?

### SUPPLEMENTARY EXERCISES ON WATER

#### Supplementary Exercise 11 — Preparation and Properties of Distilled Water — Teacher's Exercise

**MATERIALS.** — Water containing a little of three impurities — dirt, calcium chloride, and sodium sulfate; potassium permanganate, silver nitrate, barium chloride, and ammonium oxalate solutions.

**APPARATUS.** — Liebig condenser, etc., as in Fig. 30.

**I. Preparation.** — Fill the flask *A* half full of the water containing the three impurities mentioned above, add a few short pieces of glass tubing to insure even boiling, and connect with the condenser at *B* as shown in Fig. 30. Attach

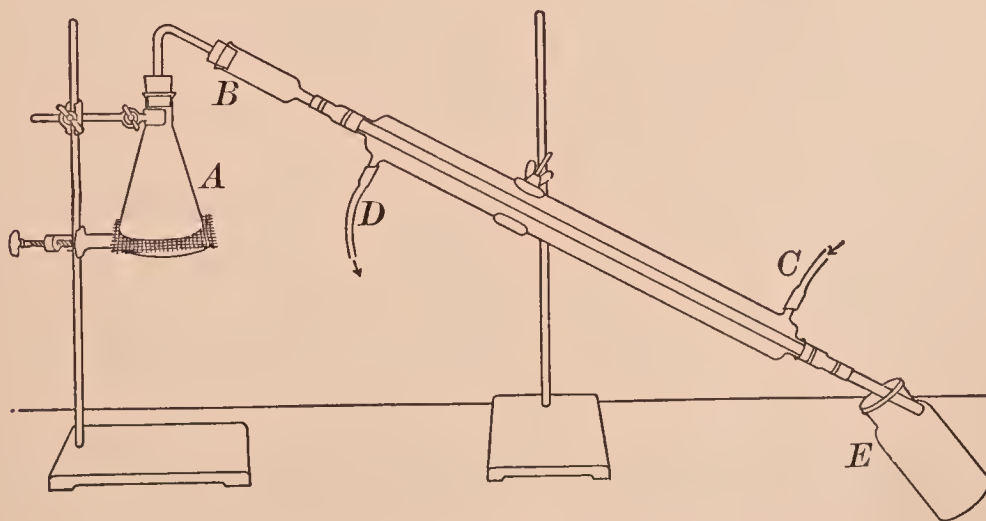

FIG. 30. — Liebig condenser arranged to distil water

the inlet (lower) tube *C* to the faucet, fill the condenser slowly, and regulate the current so that a small stream flows continuously from the outlet tube *D* into the sink or waste pipe.

Heat the liquid in *A* to boiling. The steam will condense as it passes through the inner tube, and drop off as the dis-



tillate, into the receiver *E*. Reject the first 5 or 10 cc. of the distillate; they may contain impurities. As the distillate collects in the clean receiver *E*, proceed with the tests as in II.

**II. Properties.** — (a) While the distillate is collecting, test the impure water for **organic matter**. Put 10 cc. of the impure water in a test tube, add a few drops of concentrated sulfuric acid, and enough potassium permanganate solution to color the mixture a light reddish purple. Mix well by stirring with a glass rod. Grasp the test tube with the test tube holder and heat gently until the liquid begins to boil, taking care to remove the test tube from the flame occasionally to prevent the liquid from spurting out. If organic matter is present, the color of the solution will be changed to brown.

Test in the same way 10 cc. of the distilled water, taking care to use a very clean test tube. Compare the results.

(b) Test separate portions (about 10 cc.) of the impure water for different kinds of **mineral matter**. In a similar way test the distilled water and compare the corresponding tests.

(1) **Chlorides.** — Add a few drops of silver nitrate solution, and note the result. The white, curdy solid is silver chloride, which is formed by the reaction between silver nitrate and the dissolved chloride. All soluble chlorides produce the same result. (**Precaution.** — In testing for a chloride it is best to add also some nitric acid to dissolve substances which might be mistaken for silver chloride.)

(2) **Sulfates.** — Add a few drops of barium chloride solution, and note the result. The white, fine precipitate is barium sulfate, which is formed by the chemical action between barium chloride and the dissolved sulfate; its formation is a test for any sulfate in solution.

(3) **Calcium (or lime) compounds.** — Add a few drops of ammonium oxalate solution, and note the result. The white precipitate is calcium oxalate. Its formation serves as a test for dissolved calcium compounds.

*Write a brief description of this exercise in your laboratory notes.*

*Write also the test for (1) a chloride, (2) a sulfate, and (3) a calcium compound.*



## Optional Exercises

1. Test different samples of water for impurities, as in (a) and (b).
2. Taste of distilled water. Compare with ordinary drinking water. Why does distilled water have such a flat taste?

### Supplementary Exercise 12 — Purification of Water — Teacher's Exercise

**MATERIALS.** — Water (100 cc.) rendered turbid with fine clay; cotton, sand, powdered charcoal, alum solution, ammonium hydroxide. For (d) bad-smelling water, chlorine water.

**APPARATUS.** — Two funnels, test tube fitted with a cork (for (d)).

(a) Put a loose plug of cotton in the apex of a funnel, fill the funnel one-fourth full of sand, pour 25 cc. of the turbid water on the sand, and catch the filtrate in a test tube. (Meanwhile do (b), etc.) Note the result. Compare the filtrate with the sample.

(b) Proceed as in (a), using powdered charcoal instead of sand. Note the result. Compare the filtrates from (a) and (b) with the sample.

(c) Fill a large test tube about four-fifths full of the turbid water. Add about 5 cc. of alum solution and mix well. Then add about 10 cc. of ammonium hydroxide, and mix well again. Let the mixture stand undisturbed several minutes. Note the result. Compare the upper liquid (1) with the sample and (2) with the filtrates from (a) and (b).

(d) Add 2 cc. of chlorine water to a test tube nearly full of bad-smelling water, cork, shake well. Note the result. Compare with the sample.

*Write a brief account of this exercise in your laboratory notes.*

### Supplementary Exercise 13 — Anhydrous Compounds

**MATERIALS.** — Hydrated (crystallized) copper sulfate.

(a) Pulverize a little hydrated copper sulfate and note the color. Put it in a test tube, hold the tube horizontal, and spread the powder along the tube. Hold the mouth of the

tube slightly lower than the other end, and heat gently. Begin to heat at the closed end and move the tube in the flame so that all the liberated water is finally driven from the tube. Note the color of the anhydrous solid. Let the tube cool.

(b) When the tube is cool, cautiously add a little water, and let it run down upon the solid. Note the effect of the water on the color of the solid.

*Write a brief account of this exercise in your laboratory notes.*

*Write answers to these questions in your laboratory notes.*

(1) *What is the difference between a hydrated and an anhydrous compound?* (2) *What is the color of hydrated copper sulfate? Dehydrated? Anhydrous?*

### **Supplementary Exercise 14 — Efflorescence — Teacher's Exercise**

**MATERIALS.** — Sodium carbonate, sodium sulfate, ferrous sulfate, potassium ferrocyanide, barium chloride, magnesium sulfate.

Put a fresh, or a recently broken, crystal of several of the substances on a piece of filter paper, and label each. Let them remain exposed to the air for an hour or more. Note any marked change in the appearance.

*Write an account of this exercise in tabular form in your laboratory notes.*

*Write also answers to these questions. (1) What does the change, if any, show about the air? About the crystal? (2) To what is the change due?*

### **Supplementary Exercise 15 — Efflorescence and Deliquescence — Teacher's Exercise**

**MATERIALS.** — Crystallized copper sulfate, concentrated sulfuric acid, sodium hydroxide.

**APPARATUS.** — 4 test tubes fitted with corks, thread, copper or iron wire.

**A.** Select two pieces of crystallized copper sulfate which will just slip into a test tube. Tie a thread around each piece. Put 10 cc. of water into one test tube, and 10 cc. of

concentrated sulfuric acid into the other, taking care not to leave any drops on the inside of the test tube, and insert the cork tightly (Fig. 31); smear a little vaseline around the upper edge of the test tube containing the acid to make the joint air tight.

Let the test tubes stand in the rack undisturbed for several hours (or until the next laboratory period), and then examine each solid. Compare them with each other and with a sample of the original substance. Note the change, if any, in each case; note also the degree of change.

**B.** Proceed as in **A**, using sodium hydroxide. Wind the wire around the solid and attach the wire to the thread. Observe, as in **A**.

*Write a brief account of this exercise in your laboratory notes.*

*Write also answers to these questions. (1) How do **A** and **B** differ? (2) How can solids be kept (a) dry, (b) hydrated, (c) wet, (d) anhydrous?*



FIG. 31.—Apparatus for showing efflorescence and deliquescence

### Supplementary Exercise 16 — Supersaturated Solution — Teacher's Exercise

**MATERIAL.** — Sodium thiosulfate.

**APPARATUS.** — Test tube fitted with a cork.

Fill a test tube half full of crystallized sodium thiosulfate and add 2 or 3 cc. of water. Warm slowly until all the solid has dissolved. Pour the solution into a warm, clean, dry test tube, insert a cork, and let it stand undisturbed until cool. Note the change in the solution, if any. Drop in a small crystal of sodium thiosulfate and watch for a definite change. Note what happens. Observe the final result.

*Write a brief account of this exercise in your laboratory notes.*

*Write also answers to these questions. (1) What is the difference between a saturated and an unsaturated solution? (2) How could you determine whether a cold solution is saturated, unsaturated, or supersaturated?*



## Supplementary Exercise 17 — Qualitative Composition of Water — Teacher's Exercise

MATERIALS. — Chlorine water (see Supp. Exer. 19), joss stick.

APPARATUS. — As in Fig. 32. The tube is about 1 m. long and closed at one end.

Fill the tube with chlorine water, cover the open end with the thumb or finger, invert the tube, and immerse the open end in a mortar or an evaporating dish, which should be nearly full of chlorine water (Fig. 32). Clamp the tube in an upright position, and stand the whole apparatus where it will receive the direct sunlight for several hours. Bubbles of gas will collect at the top.

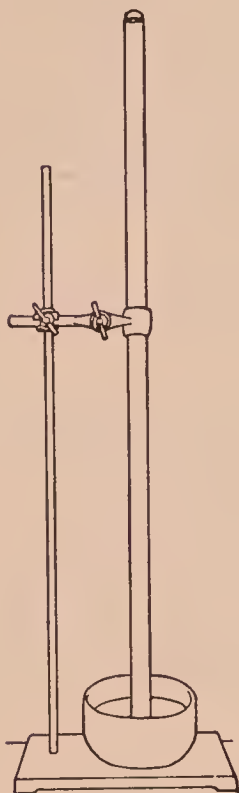

FIG. 32. — Apparatus for showing that oxygen is a constituent of water

When sufficient gas for a test has collected, unclamp the tube, cover the open end with the thumb or finger, invert, and put a glowing joss stick into the gas. Repeat as long as any of the gas remains. Note the result.

*Write answers to these questions in your laboratory notes. (1) What gas is produced by the interaction of chlorine and water? (2) What evidence about the composition of water is given by (a) interaction of water and sodium and (b) reduction of copper oxide by hydrogen (or carbon)? (3) Of what two elements is water composed?*

## EQUIVALENT WEIGHTS — FORMULA

### Exercise 20 — Equivalent Weight of Zinc

MATERIALS. — Zinc, dilute sulfuric acid.

APPARATUS. — As in Fig. 33, pneumatic trough (not zinc), thermometer, barometer.

OBJECT. — To find the number of grams of zinc chemically equivalent to 1 gram of hydrogen.



Copy the form of RECORD (given below) in your laboratory notes and enter each item as soon as the weighing, measuring, or reading is made.

Construct and arrange the apparatus (Fig. 33) to collect a gas over water, and have it inspected by the Teacher.

Obtain a piece of weighed zinc from the Teacher, or weigh from 0.45 to 0.5 gm. of zinc on the balance. Take a single piece and weigh it exactly. Enter in the RECORD as *Zn*.

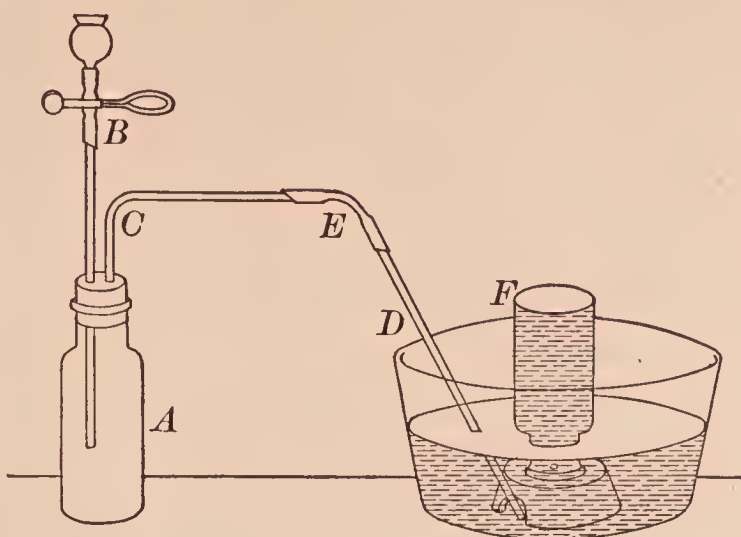

FIG. 33. — Apparatus for finding the equivalent weight of zinc

### RECORD

Weight of zinc taken ( <i>Zn</i> ) . . . . .	gm.
Observed volume of hydrogen ( <i>V'</i> ) . . . . .	cc.
Temperature ( <i>t</i> ) . . . . .	°
Pressure ( <i>P'</i> ) . . . . .	mm.
Vapor pressure ( <i>a</i> ) . . . . .	mm.
Corrected volume of hydrogen ( <i>V</i> ) . . . . .	cc.
Weight of corrected volume of hydrogen ( <i>W</i> ) . . . . .	gm.
Equivalent weight of zinc ( <i>E</i> ) . . . . .	gm.

Put the weighed zinc into the bottle *A*. Fill the bottle with water and insert the stopper with all its tubes. Next fill the remainder of the apparatus with water by filling the cup with water and then admitting it repeatedly until all air is forced out of the bottle and tubes; take care never to let the water in *B* fall below the lower opening of the cup. Note that the inner end of the tube *C* does not extend below the stopper — important.

Fill a 250 cc. bottle with water and invert it upon the support in the trough (a zinc trough must not be used). Put the end of the delivery tube under the support and ask

for a final inspection. Heat about 50 cc. of dilute sulfuric acid in a test tube. Fill the cup and introduce the hot acid (Care!) in separate portions slowly into the bottle *A*, taking the same precaution as before. The liberated hydrogen will slowly accumulate in the receiving bottle. (NOTE. — While the hydrogen is being evolved, **Exercise 21** may be done.)

Let the action continue until the zinc is used up; disregard a minute speck or two which may be left from the zinc. Then force over into the collecting bottle all gas in the apparatus by admitting water carefully as before. Lay a piece of dry filter paper upon the bottom of the bottle, grasp the bottle firmly, carefully joggle it to dislodge any gas bubbles which may be underneath the support, slide the bottle from the support, and lower it into the water until the water is at the same level inside and outside the bottle; then slip two pieces of filter paper beneath the bottle, cover the mouth firmly, lift the bottle from the trough and stand it, right side up, upon the desk. Stand a thermometer in the bottle, and after a few minutes read the thermometer while the bulb is in the water; enter as *t*.

Fill a 250 cc. graduate exactly to the mark with water, remove the thermometer from the bottle, and very carefully fill the bottle with water from the graduate; read and enter (as *V'*) the exact volume of water added; this is numerically the same as the volume of hydrogen liberated. Read the barometer, and enter as *P'*. Find the vapor pressure corresponding to the observed temperature (see APPENDIX, § 1), and enter as *a*.

Correct the observed volume (*V'*) of hydrogen for temperature, pressure, and vapor pressure, and enter as *V*.

Since 1000 cc. of dry hydrogen weigh 0.09 gm., the weight (*W*) of the corrected volume of hydrogen (*V*) is found by the proportion

$$1000 : V :: 0.09 : W.$$

And the weight of zinc equivalent (*E*) to 1 gram of hydrogen is found by  $W : Zn :: 1 : E$ . Enter this weight (the equivalent weight) of zinc as *E*.

Submit the result to the Teacher before taking the apparatus apart.

*Write a brief account of this exercise in your laboratory notes.*

### Optional Exercises

1. Calculate the atomic weight of zinc by multiplying the equivalent weight (found in this exercise) by 2.
2. Compare this calculated atomic weight with the approximate atomic weight.
3. Calculate, as in 1, from the class average.
4. Compare the number obtained in 3, as in 2.

### ★Exercise 21 — Equivalent Weight of Magnesium

**MATERIALS.** — Magnesium ribbon, concentrated hydrochloric acid.  
**APPARATUS.** — A 100 cc. tube, pneumatic trough (not zinc), thermometer, barometer, tall jar (*e.g.* 1000 cc. graduate).

**OBJECT.** — To find the number of grams of magnesium equivalent to 1 gm. of hydrogen.

Copy in your laboratory notes the form of **RECORD** as in **Exercise 20**, and enter the items, when available, in the proper place.

Obtain a piece of weighed magnesium from the Teacher or weigh accurately from 0.06 and 0.07 gm. of magnesium ribbon, preferably in a single piece. Enter the exact weight as *Mg*. Have the trough (not zinc) half full of water.

Pour 8 cc. of concentrated hydrochloric acid into the 100 cc. tube and fill the tube completely with cold water. Put the magnesium into the water in the tube, cover the end of the tube with the thumb or finger, invert, and stand it in the trough, but keep the end loosely closed to prevent the magnesium from slipping out. As the acid sinks through the water and reaches the magnesium, action begins vigorously. Hydrogen rises rapidly in the tube and usually carries the magnesium with it. Watch the operation, and shake the tube to prevent the magnesium from sticking to the inside. If a piece of magnesium should stick to the inside of the tube, close the end of the tube tightly with the finger, lift it from



the water, incline it enough to let the liquid run down and loosen the magnesium, then quickly put the end of the tube beneath the water, and remove the finger.

When all the magnesium has disappeared, close the end of the tube, remove (Care!) the tube to a tall jar of water, and let it stand five or more minutes; then, by a clamp (without touching the tube with the hands), adjust the height so that the water levels are the same inside and outside of the tube. Read the volume of hydrogen, and enter as the observed volume ( $V'$ ). Read the barometer and the thermometer (keeping the bulb in the water). Enter as  $P'$  and  $t$ .

Correct the observed volume ( $V'$ ) for temperature, pressure, and vapor pressure, and enter as the corrected volume ( $V$ ). Find the weight ( $W$ ) of this volume ( $V$ ) of hydrogen as in **Exercise 20**. Calculate the weight of magnesium equivalent to 1 gm. of hydrogen, as in **Exercise 20**. Enter this weight as  $E$ .

Submit the result to the Teacher before letting out the gas.

*Write a brief account of this exercise in your laboratory notes.*

### Optional Exercises

As in **Exercise 20**.

#### **Exercise 22 — Formation of the Compound Copper Sulfide**

**MATERIALS.** — Fine copper wire (about 2 m. (6 ft.)), powdered sulfur.

**APPARATUS.** — Porcelain crucible and cover, crucible block, triangle, balance and weights.

**OBJECT.** — To find the weight of sulfur that combines with a certain weight of copper, and calculate the weight of sulfur that would combine with 1 gram-atomic-weight of copper (*i.e.* with 63.57 gm.).

Copy the form of **RECORD**, as given below, in your laboratory notes. When you weigh, take the notebook to the balance and enter all weights in the **RECORD** as soon as the weighing is made. In weighing ask directions or follow **APPENDIX, § 8**.



Clean and dry a porcelain crucible and cover. Carry it to the balance in the crucible block (Fig. 34). Weigh the *uncovered* crucible accurately on the balance. Coil the piece of copper wire into a flat spiral, put it in the crucible, and weigh both.

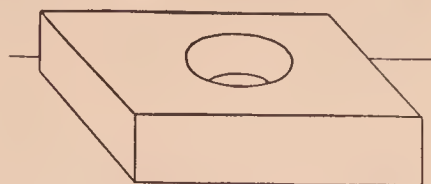

FIG. 34. — Crucible block

Put the crucible on the crucible block, and carry it, together with the cover, iron stand, ring, triangle, and burner, to the hood. Fill the crucible half full of powdered sulfur, stand it on the triangle (Fig. 35), put on the cover, and heat gently to melt the sulfur. Remove the cover, and if the copper wire is not completely covered with sulfur, add more sulfur. Put on the cover, and heat the crucible as long as the blue flame of burning sulfur is seen between the crucible and cover. Continue to heat two or three minutes more, especially the upper part of the crucible. Then take off the cover, and if any unburned sulfur is seen, heat until all the sulfur is gone.

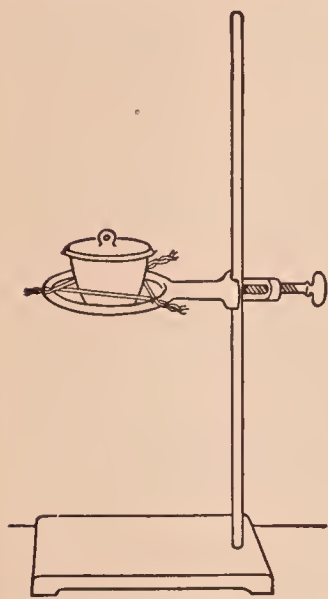

FIG. 35. — Covered crucible on triangle

Let the crucible cool. Carry it to the balance as before, and weigh (without cover). Complete the RECORD.

Calculations. (1) Find the weight of sulfur that would combine with 63.57 gm. of copper by this proportion :

Wt. of Copper : Wt. of Sulfur :: 63.57 : X., X = gm. of sulfur.

(2) Find the per cent of copper and of sulfur in the product (copper sulfide) thus : —

$$\% \text{ of copper} = \frac{\text{Wt. of copper}}{\text{Wt. of copper sulfide}} \times 100 =$$

$$\% \text{ of sulfur} = \frac{\text{Wt. of sulfur}}{\text{Wt. of copper sulfide}} \times 100 =$$

(3) Find the formula of copper sulfide thus: Divide the per cent of each element by the corresponding atomic weight, and reduce the quotients to the smallest whole numbers. These numbers are the subscripts of the corre-

sponding elements in the formula. (NOTE. — Unless the exercise is done accurately, the correct formula is not readily calculated from the per cents found.)

RECORD		GRAMS
Wt. of crucible and copper . . . . .		
Wt. of crucible . . . . .		_____
Wt. of copper . . . . .		
Wt. of crucible and contents after heating . . . . .		
Wt. of crucible . . . . .		_____
Wt. of copper sulfide . . . . .		
Wt. of copper . . . . .		_____
Wt. of sulfur . . . . .		

*Write in your laboratory notes the results of (1), (2), (3).*

### SUPPLEMENTARY EXERCISE ON EQUIVALENT WEIGHTS

#### Supplementary Exercise 18 — Equivalent Weight of Aluminum

Proceed as in **Exercise 20**. Use about 0.17 gm. of aluminum (taking care to weigh exactly the amount used). Use hot concentrated hydrochloric acid instead of dilute sulfuric acid. Record and calculate as in **Exercise 20**.

#### Optional Exercises

As in **Exercise 20**. (In 1 the multiplier is 3.)

### CHLORINE AND HYDROCHLORIC ACID

#### ★**Exercise 23** — Preparation and Properties of Chlorine

**MATERIALS.** — Concentrated hydrochloric acid, potassium permanganate, wax taper, iron thread, copper wire (15 cm. long), colored cloth, piece of newspaper, litmus paper, cotton, turpentine. (NOTE. — Bleaching powder (10 gm.) and concentrated sulfuric acid (10 cc.) — **CARE** — may be used in place of potassium permanganate and hydrochloric acid.)

**Caution.** — Do this exercise in the hood.

**I. Preparation.** — Warm four dry bottles, cover the bottom of each with a thin layer of crystallized potassium permanganate, add 5 cc. of concentrated hydrochloric acid to each (see NOTE above), and cover with a piece of filter paper pressed down to form a loose cap. Chlorine will slowly fill the bottles. When the (greenish) color shows that a bottle is full of the gas, proceed at once with it as in II (a). Use the other bottles when full.

**II. Properties.** — (a) Remove the paper from a bottle of chlorine and thrust a blazing wax taper into the gas. Observe the result at once, *e.g.* effect on the gas and the taper, and formation of smoke.

(b) Using the same bottle as in (a), hold a lighted wax taper just inside the bottle. Move it up and down slowly. If it goes out, relight it, and continue. (If a taper is unsatisfactory, use a candle attached to a wire.) Observe the result, especially the formation of white and of black smoke.

(c) Twist one end of a copper wire around a wad of iron thread (Fig. 36), heat the edge of the wad for an instant in the flame, and quickly lower it into another bottle of chlorine. Observe the result, especially the evidence of chemical action.

(d) Into the third bottle of chlorine hang (by a wire) pieces of colored cloth, litmus paper (both colors), newspaper, and paper containing writing in lead pencil, ink (black and red) — all moistened with water; cork or cover the bottle. Let the whole remain undisturbed for a few minutes (*e.g.* while (e) is being done). Then note what is bleached and what is not.

(e) Twist one end of the copper wire around a wad of cotton, saturate the cotton with turpentine, and lower the cotton into a bottle of chlorine. Observe at once the formation of white smoke and then the conspicuous result. (This experiment works well if the turpentine is warm (Care!) and the bottle is *full* of chlorine.)



FIG. 36. — Wads of cotton and iron thread for studying the properties of chlorine



NOTE. — As soon as II (e) has been completed, fill each bottle with water (in the hood) and pour the contents at once into a waste jar in the hood.

Write in your laboratory notes answers to these questions. (1) What is the color of chlorine? Is this gas heavier or lighter than air? Does it burn? Does it support ordinary combustion? (2) Knowing that wax and turpentine consist of compounds of carbon and hydrogen, how do you explain the observations in (b) and (e)? (3) What was bleached and not bleached in (d)? (4) What compound was formed in (c)?

### ★Exercise 24 — Preparation and Properties of Hydrogen Chloride and Hydrochloric Acid

MATERIALS. — Sodium chloride, concentrated sulfuric acid, litmus paper (blue), ammonium hydroxide.

APPARATUS. — As in Fig. 37 (or Fig. 38). *A* is a 250 cc. Erlenmeyer flask which stands on a gauze-covered ring; the parts lettered *B*, *C*, *D*, *E* have been used in preceding experiments. *F* is a piece of stiff paper.

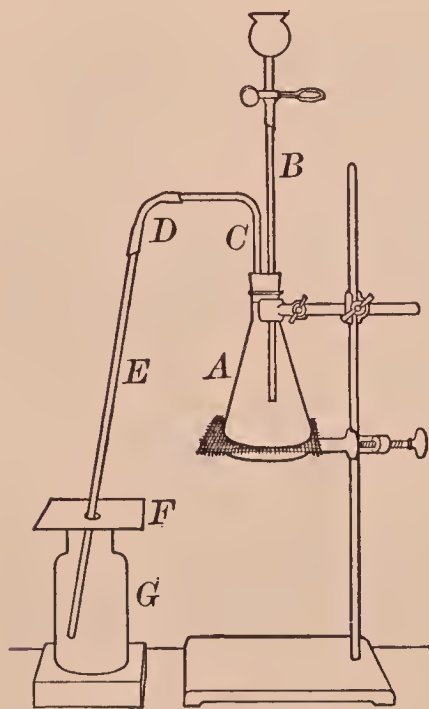

FIG. 37. — Apparatus for preparing hydrogen chloride and hydrochloric acid

NOTE. — Perform this experiment in the hood.

I. Preparation. — (1) **Hydrogen chloride.** — Put 8 cc. of water into a small bottle or an evaporating dish, cautiously add 10 cc. of concentrated sulfuric acid, and stir until the two are mixed. While this mixture is cooling, weigh 10 gm. of sodium chloride, slip it into the flask, and arrange the apparatus as shown in Fig. 37. If a straight thistle tube is used (Fig. 38), the lower end must be below the surface of the acid.

Pour half of the cold acid through the funnel into the flask, let it settle through the sodium chloride, and then add the remaining acid. Heat the flask gently. Hydrogen chloride



passes into the bottle *G*, which should be removed when full. (A piece of moist blue litmus paper held near the mouth of the bottle will show when it is full. Let the gas enter a minute or so after the first test.) Collect three bottles of the gas, cover each tightly, when filled, with a piece of dry filter paper, and set aside for II.

(2) **Hydrochloric acid.** — As soon as the third bottle of gas has been collected, put in its place a bottle one-fourth full of water. Adjust the delivery tube *E* so that the lower end is a short distance above the surface of the water. Continue to heat the flask at intervals, and the gas will be absorbed by the water. Shake the bottle occasionally. Meanwhile perform II.

**II. Properties of hydrogen chloride.** — (a) Insert a blazing joss stick once or twice into a bottle of the gas, and observe the effect on both joss stick and gas.

(b) Using the bottle from (a), hold a piece of wet filter paper near the mouth (or drop it inside). Observe the result.

(c) Invert a bottle of the gas, and stand it in a vessel of water (*e.g.* the pneumatic trough). Shake the bottle vigorously up and down, still keeping its mouth under the water. Observe the change inside the bottle. Cover the mouth of the bottle with the hand, invert, and stand it on the desk. Test the contents (1) with blue litmus paper and (2) by adding a few drops of silver nitrate solution. Note each result.

(d) Drop into the remaining bottle of gas a piece of filter paper wet with ammonium hydroxide. Note the result.

**III. Properties of hydrochloric acid.** — Remove the bottle in which the hydrogen chloride is being absorbed. This liquid is dilute hydrochloric acid.

Determine its general properties, *e.g.* taste (cautiously), action with litmus, with magnesium (using 10 cc. of the hydro-

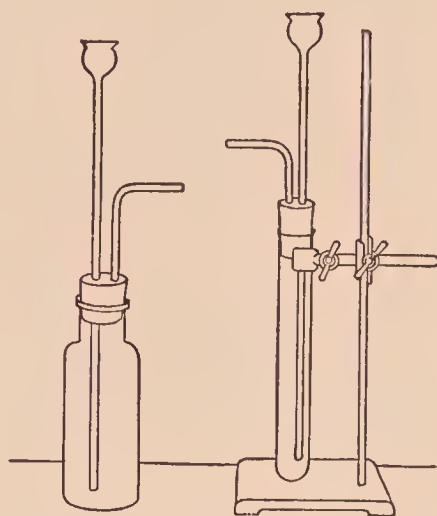

FIG. 33. — Simple apparatus for hydrogen chloride and hydrochloric acid

chloric acid), and with silver nitrate solution. Note the result in each case.

NOTE. — As soon as II (b) has been performed, add water to the flask or test tube, shake well, and pour the contents into a waste jar in the hood.

*Write a brief description of I in your laboratory notes.*

*Write answers to these questions in your laboratory notes.*

(1) *What is (a) the verbal and (b) the chemical equation for the reaction in I?* (2) *Does hydrogen chloride (a) burn or (b) support combustion?* (3) *What is the explanation of the result in II (b)?* (4) *What property of hydrogen chloride is shown by the first part of II (c)?* (5) *What are the chemical equations for the reactions in II (c) (2) and (d)?*

### Optional Exercises

1. Summarize the properties of hydrochloric acid.
2. Enumerate several physical properties of hydrogen chloride.

### ★Exercise 25 — Tests for Hydrogen Chloride, Hydrochloric Acid, and Chlorides

(a) Recall a specific property which would serve as a test for hydrogen chloride.

(b) As in (a) for hydrochloric acid.

(c) Apply the silver nitrate test for a chloride by adding a few drops of this reagent to a few cubic centimeters of a solution of several chlorides in separate test tubes (*e.g.* ammonium chloride, ferric chloride, and calcium chloride). Note each result.

NOTE. — It is desirable, though not always necessary, to add nitric acid to dissolve certain compounds (*e.g.* silver carbonate) which might be formed in testing with silver nitrate.

*Write in your laboratory notes a brief, accurate statement of the test for hydrochloric acid and soluble chlorides.*

*Write also the equation for the reaction.*

## ★Exercise 26 — Insoluble Chlorides

MATERIALS. — Silver, lead, and mercurous nitrate solutions.

(a) Put about 5 cc. of silver nitrate, lead nitrate, and mercurous nitrate in separate test tubes, and label each tube. Add 5 cc. of dilute hydrochloric acid to each solution, shake, and note the result. Note the color of each precipitate. Decide on a name for each.

(b) Shake well, and pour about half of each precipitate into separate test tubes. Save the rest of the precipitates for (c).

Fill each of the three test tubes half full of water, and heat to boiling. Note which chloride dissolves in hot water.

(c) Fill each of the test tubes saved in (b) nearly full with ammonium hydroxide. Shake well. Warm gently. Note the effect of ammonium hydroxide on each chloride.

(d) Optional. Test unknown solutions for (1) a chloride and (2) lead, silver, and mercurous compounds. Note each result.

*Write answers to these questions in your laboratory notes.*

(1) *In what are these three chlorides insoluble? (2) How could the three chlorides be separated from one another? (3) What is a test for (a) a soluble chloride, (b) an unknown solution supposed to contain a chloride, (c) a lead compound, (d) a silver compound, (e) a mercurous compound, (f) lead chloride, (g) silver chloride, (h) mercurous chloride? (4) How can a chloride be distinguished from a sulfate?*

### SUPPLEMENTARY EXERCISES ON CHLORINE AND HYDROCHLORIC ACID

#### Supplementary Exercise 19 — Preparation and Properties of Chlorine — Teacher's Exercise

MATERIALS. — Concentrated hydrochloric acid, 10 gm. of manganese dioxide, and as in **Exercise 23** (except potassium permanganate).

APPARATUS. — As in Fig. 37. If desired, the optional apparatus shown in Fig. 38 may be used.

**Caution.** — As in **Exercise 23**.

**I. Preparation.** — Slip the manganese dioxide into the flask. Arrange the apparatus as shown in Fig. 37. Intro-



duce enough concentrated hydrochloric acid through the dropping tube *B* to cover the manganese dioxide. Heat the flask *A* gently with a small flame. Avoid heating so high that steam or hydrogen chloride is evolved.

Chlorine passes into the bottle *G*, which should be removed when full (as seen by the color) and covered tightly with a piece of filter paper; the bottle may be easily removed by holding the paper cover *F* in one hand and pulling the bottle *G* aside, bending the whole delivery tube at the same time at the rubber connection *D*. If the evolution of gas slackens, introduce more acid. Collect four bottles, and proceed at once as in II.

**II. Properties.** — As in **Exercise 23**, (*a*) to (*e*).

### Supplementary Exercise 20 — Chlorine Water — Teacher's Exercise

**MATERIALS.** — Chlorine water, litmus paper, colored cloth or paper, ink-stained cloth, gold leaf (for (*b*)).

Obtain about 50 cc. of chlorine water, or prepare it by letting the gas bubble for fifteen minutes or more through a bottle half full of water.

(*a*) Try the bleaching action of chlorine water on litmus paper, bright colored cloth or paper (which is not decolorized by water alone), and a piece of ink-stained cloth. Note the results.

(*b*) Determine the solvent power as follows: Stand a test tube in the rack. Moisten the end of a glass rod, touch it to a small piece of gold leaf, hold the rod with the adhering gold leaf inside a test tube, and wash the gold leaf into the test tube by pouring about 15 cc. of chlorine water down the rod. Remove the rod. Warm the test tube gently and shake until a definite change in the gold is observed. Note the final result.

*Write answers to these questions in your laboratory notes.*

- (1) *What effect has chlorine water on many colored substances?*
- (2) *On gold?* (3) *What compound is formed in (b)?*



## Supplementary Exercise 21 — Bleaching with Bleaching Powder — Teacher's Exercise

**MATERIALS.** — Bleaching powder, dilute sulfuric acid, colored cloth.

**APPARATUS.** — 3 dishes (small), glass rod.

Put a little bleaching powder into one dish and add enough water to make a thin paste. Fill the second dish one-third full of dilute sulfuric acid, and the remaining one full of water.

Press the lower half of the colored cloth into the bleaching powder with the glass rod, and then into the acid, passing it back and forth several times. Finally wash the cloth thoroughly in the water, squeeze out the excess of water, and compare the upper and lower parts of the cloth. Note the change in color. Dry the cloth and paste it in your laboratory notebook. (If the change is not marked, try other kinds of cloth.)

*Write a brief description of this exercise in your laboratory notes.*

## Supplementary Exercise 22 — Preparation and Properties of Hydrogen Chloride

**MATERIALS.** — Sodium chloride, concentrated sulfuric acid, silver nitrate solution, litmus paper, ammonium hydroxide.

**I. Preparation.** — Put a few grams of sodium chloride in a test tube, stand the tube in the rack, and carefully add several cubic centimeters of concentrated sulfuric acid. Hydrogen chloride is evolved.

**II. Properties.** — (a) Hold a piece of blue litmus paper at the mouth of the test tube. Observe the result.

(b) Blow the (moist) breath across the mouth of the tube. Hold a piece of wet filter paper in the gas. Observe the result in each case.

(c) Hold a glass rod moistened with ammonium hydroxide in the gas. Observe the result.

(d) Moisten a clean glass rod with silver nitrate solution and hold it in the gas. Observe the result.

Write answers to these questions in your laboratory notes. (1) What is (a) the verbal and (b) the chemical equation for the reaction in I? (2) What causes the change in II (a) and (b)? (3) What solid compound is formed in II (c)? What is the chemical equation? (4) As in (3) applied to II (d)?

### Supplementary Exercise 23 — Aqua Regia — Teacher's Exercise

MATERIALS. — Gold leaf, concentrated nitric and hydrochloric acids.

Touch a small piece of gold leaf with the end of a moist glass rod, and wash the gold leaf into a test tube by pouring a few cubic centimeters of concentrated hydrochloric acid down the rod. Warm gently. Note if the gold dissolves.

Wash another piece of gold leaf from a clean glass rod into another test tube with concentrated nitric acid. Warm as before, and note if the gold dissolves.

Prepare aqua regia by pouring the contents of one tube cautiously into the other. Warm gently, and note if the gold dissolves.

Write a brief account of this exercise in your laboratory notes.

Answer also these questions. (1) What compound of gold is formed by its interaction with aqua regia? (2) Would chlorine water act like aqua regia on gold?

### Supplementary Exercise 24 — Types of Chemical Change — Teacher's Exercise

MATERIALS. — For (a) mercury, iodine; for (e) optional.

(a) Direct combination. Put a drop of mercury in a mortar, add a small fragment of iodine, grind the two together, and note the result. The product is a compound of mercury and iodine.

(b) Direct decomposition. As in Supplementary Exercise 1.

(c) Simple replacement. As in Supplementary Exercise 8.

(d) Double decomposition. As in Supplementary Exercise 9 (b).

(e) Optional. (1) Heat magnesium in air. (2) Put a clean nail in copper sulfate solution. (3) Mix silver nitrate and calcium chloride solutions. (4) Heat lead nitrate in a test tube. (5) Mix calcium chloride and sodium carbonate solutions. Note each result.

*Write equations for (a) to (d) in your laboratory notes.*

*Write also (if available) the results in (e) with equations, and state what type of chemical change each numbered part illustrates.*

## AIR — NITROGEN

### Exercise 27 — Per Cent of Oxygen in Air — Teacher's Exercise

**MATERIALS.** — Solutions of pyrogallic acid (10 per cent) and sodium hydroxide (50 per cent).

**APPARATUS.** — As in Fig. 39; pneumatic trough half full of water at room temperature, 250 and 25 cc. graduated cylinders. The bottle holds about 250 cc. and is provided with a tightly fitting one-hole rubber stopper through which passes a glass plug. The plug is about 10 cm. (4 in.) long and is made by closing both ends of a glass tube; it should fit tight.

**OBJECT.** — To find the volume of oxygen absorbed from a measured volume of air.

Copy the form of RECORD, as given below, in your notebook and enter each volume as soon as the readings are made.

First find the volume of the bottle. Fill the pneumatic trough with water and add water, if necessary, to bring the temperature to that of the room. Fill the bottle full of water from the pneumatic trough. Push the stopper into the bottle as far as it will go, insert the glass plug until the inner end is flush with the inner surface of the stopper, and draw a line around the stopper with a pencil to mark its position (Fig. 39). Remove the plug and then the stopper carefully, to avoid loss of water. Pour water from the bottle into the



FIG. 39. — Apparatus for finding the per cent of oxygen in air



250 cc. graduate until the graduate is full (to the 250 cc. mark) or the bottle is empty; read the volume. If the bottle holds more than 250 cc., the rest of the water in the bottle may be poured into the 25 cc. graduate. Enter the total volume of the bottle in the RECORD.

### RECORD

a.	Volume of bottle . . . . .	cc.
b.	Volume of original solution (total) . . . . .	cc.
c.	Volume of air taken ( $a - b$ ) . . . . .	cc.
d.	Volume of final liquid . . . . .	cc.
e.	Volume of water which entered ( $d - b$ ) . . . . .	cc.
f.	Per cent of water which entered ( $e \div c$ ) . . . . .	

Therefore:—

g.	Per cent of oxygen in the sample of air . . . . .	
h.	Per cent of nitrogen ( $100 - g$ ) . . . . .	

Measure exactly 10 cc. of the pyrogallie acid in the 25 cc. graduate, and pour it carefully into the bottle. Measure also exactly 20 cc. of the sodium hydroxide solution, and pour it into the bottle. (**Caution.** — The sodium hydroxide solution is corrosive. Do not spill it on the hands or clothing.) Insert the rubber stopper (with its plug) quickly to the proper mark.

Shake the bottle vigorously for a few minutes, and then invert it and watch the surface of the liquid for bubbles of air, which will enter if the apparatus leaks. If a leak is detected, ask the Teacher for directions before proceeding. If the apparatus is tight, continue the shaking for about half an hour. During this operation the oxygen is absorbed by the solution.

Place the bottle on its side beneath the water in the pneumatic trough, inclining it slightly so that the lower edge of the bottle rests upon the bottom of the trough and the hole in the stopper is *beneath* the surface of the water. With one hand grasp the bottle firmly by the neck and stopper, and with the other gradually pull out the plug to let the water run in. Water will run in quickly to fill the space left by the oxygen. Take care (1) not to pull out the stopper, (2) not to let any of the solution run out, and (3) also to keep the

hole in the stopper constantly beneath the surface of the water. After the water has stopped running in, lift out the bottle, and measure carefully the volume of the liquid in the bottle by pouring it into a graduate. Complete the entries in the RECORD.

NOTE. — This exercise disregards the argon and carbon dioxide in air.

*Write a brief account of this exercise in your laboratory notes.*

## SUPPLEMENTARY EXERCISES ON AIR

### Supplementary Exercise 25 — Air and Combustion

MATERIALS. — Wood, paper, candle.

APPARATUS. — Two blocks of wood, lamp chimney.

(a) Set fire to a small piece of wood, drop it while burning into a bottle of air, and cover the bottle at once with a block of wood. Note the final result.

(b) Proceed as in (a), using a piece of paper and another bottle. Note the final result.

(c) Attach a short candle to a block of wood with melted candle wax. Stand a lamp chimney tightly over the lighted candle. Note how the flame is affected.

(d) Hold the chimney a short distance (1 cm. or 0.5 in.) above the lower end of the (lighted) candle. Note if the candle continues to burn. Keep the chimney in the same position and cover the top with a block of wood. Note the result.

*Write answers to these questions in your laboratory notes.*

(1) *What is your conclusion from these exercises about the relation of air to combustion?* (2) *Of oxygen to combustion?*

### Supplementary Exercise 26 — Water Vapor and Carbon Dioxide in Air

MATERIALS. — Calcium chloride, calcium hydroxide solution.

(a) Place a piece of calcium chloride on a glass plate or a block of wood, and let it remain exposed to the air for an hour or more. Observe the result.

(b) Pour 25 cc. of calcium hydroxide solution into a bottle, and let it stand exposed to the air for an hour or more. Examine the surface of the liquid.

*Write in your laboratory notes the results observed in (a) and (b) and state how they show the presence of water vapor and carbon dioxide in air.*

## Supplementary Exercise 27 — Preparation and Properties of Nitrogen — Teacher's Exercise

**MATERIALS.** — Ammonium chloride, sodium nitrite, joss stick, iron thread, sulfur.

**APPARATUS.** — As in Fig. 40, three bottles.

**I. Preparation.** — Weigh 8 gm. of ammonium chloride and 10 gm. of sodium nitrite, put them in the flask, add 50 cc.

of water, and shake well. Arrange the apparatus, as in Fig. 40, to collect the gas over the water. Fill three bottles with water and invert one in the trough ready to slip into the position of G. Have two more bottles ready to replace this one. Fill the cup of the dropping funnel with water.

Heat the flask gently with a low flame, and as soon as the gas bubbles regularly through the water, slip the bottle over the hole in the support.

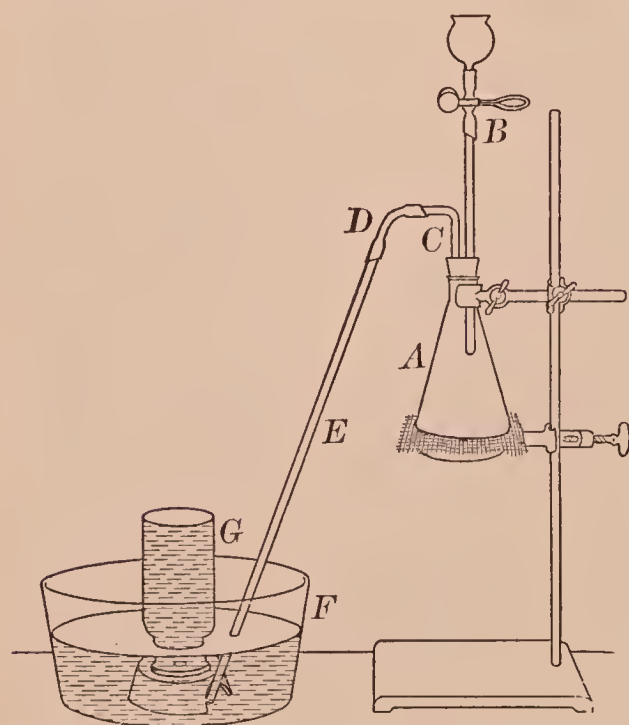

FIG. 40. — Apparatus for preparing nitrogen

Heat gently, but enough to keep the gas bubbling slowly through the water. Collect three bottles of nitrogen.

**Caution.** — If the mixture in the flask begins to froth or the gas comes off too rapidly, remove the flame and let in a little water. If it continues to froth, pinch the clamp to let out the



excess of gas ; as soon as the frothing lessens, close the clamp and heat gently. When the last bottle of nitrogen has been collected, remove the delivery tube from the water. Proceed at once with **II**.

**II. Properties.** — (a) Thrust a blazing joss stick into a bottle of the gas. Observe the result.

(b) Put a piece of sulfur in a deflagrating spoon, light the sulfur, lower it into a bottle of nitrogen, and keep it there about half a minute. Observe the result. Withdraw, and observe the result. If the sulfur is still burning, repeat. Note the result.

(c) Wind one end of a copper wire around a wad of iron thread, heat a few strands, and quickly thrust the glowing iron into a bottle of nitrogen. Observe the result.

*Write in your laboratory notes (1) the equation for I, and (2) a summary of the properties of nitrogen.*

### Optional Exercises

1. Describe briefly the preparation of nitrogen.
2. Sketch the apparatus.
3. Compare the characteristic properties of nitrogen with those of oxygen found by similar exercises.

## ACIDS, BASES, AND SALTS

### ★Exercise 28 — Behavior of Oxides with Water

**MATERIALS.** — Sulfur, calcium oxide (lime), litmus paper.

**APPARATUS.** — Deflagrating spoon.

(a) Put a little water in a bottle. Set fire to a small piece of sulfur in a deflagrating spoon and lower into the bottle. Let it burn a minute or two, then extinguish the flame by dipping the spoon into the water. Remove the spoon, cover the bottle with the hand, and shake well. Dip a glass rod into the liquid, draw the moistened end across a piece of blue litmus paper, and observe the change in color. This change in the color of blue litmus is caused by acids ;

in this case the acid is sulfurous acid, which was produced by the combination of sulfur dioxide — an acidic oxide — and water.

(b) Boil a small piece of calcium oxide with a little water in a test tube. Test with red litmus paper as in (a). If the result is indifferent, put the paper in the test tube and shake well. Observe the result in a minute or two. Compare with (a). This change in the color of red litmus is caused by bases; in this case the base is calcium hydroxide, which was produced by the combination of calcium oxide — a basic oxide — and water.

*Write a brief account of this exercise in your laboratory notes, including the equations, both verbal and chemical for the combination of these oxides with water.*

### Exercise 29 — Neutralization

MATERIALS. — Sodium hydroxide (solid), dilute hydrochloric acid, blue litmus paper.

APPARATUS. — As in Fig. 41; glass rod.

Dissolve a small piece of sodium hydroxide in an evaporating dish one-third full of water. Add a little dilute hydrochloric acid, and stir thoroughly; continue to add the acid very slowly and stir, until a drop of the well-mixed solution taken from the dish by a clean glass rod just reddens blue litmus paper. If the dish becomes too full, pour out some of the solution.

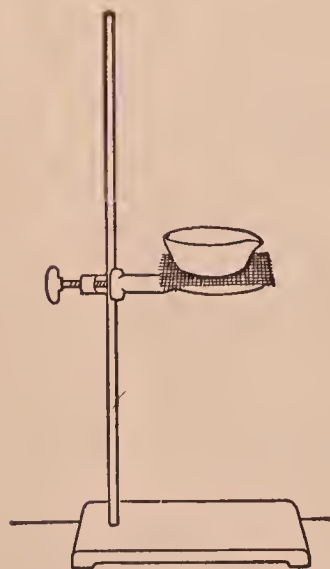

FIG. 41. — Evaporating a solution

Evaporate the solution to dryness by heating the dish on a gauze-covered ring (Fig. 41). Heat carefully toward the end to prevent spattering. When dry (or nearly so), heat strongly until the yellow color (due to the slight excess of hydrochloric acid added) disappears, then moisten the whole residue carefully with a little warm water, and heat again to evaporate the last traces of acid; add and evaporate two portions of water.

Test small portions of the residue. (1) Apply the litmus test, and note if the residue has acid, basic, or neutral properties. (2) Taste a little, and note if it has the characteristic property of an acid, base, or salt. (3) Dissolve some in water and test the solution for a chloride. Note the result. (4) Test for sodium by heating a little on a test wire in the flame. Note the result.

Write a brief description of this exercise in your laboratory notes, including answers to: (1) *Is the residue an acid, base, or salt?* (2) *What is the name of the residue?* (3) *What is the equation for the reaction?*

### Optional Exercises

1. Define neutralization. Write a typical equation.
2. If potassium hydroxide and nitric acid were used, what salt would be formed? Write the equation.
3. As in 2, if ammonium hydroxide and sulfuric acid were used? Write the equation.

### Exercise 30 — Neutralization by Titration — Teacher's Exercise

**MATERIALS.** — Phenolphthalein solution, and solutions of hydrochloric acid and sodium hydroxide (the latter of known concentration and obtained from the Teacher).

**APPARATUS.** — Burettes, beakers, and glass rod as in Fig. 42, waste beaker.

**OBJECT.** — To find the weight (in grams) of the compound HCl in 1 cc. of a solution of hydrochloric acid (*i.e.*, HCl dissolved in water) by neutralizing the acid with a solution of sodium hydroxide of known concentration.

Copy in your laboratory notes the form of RECORD given below, and enter each volume as soon as the reading is made.

Fill each burette (or start with each full)

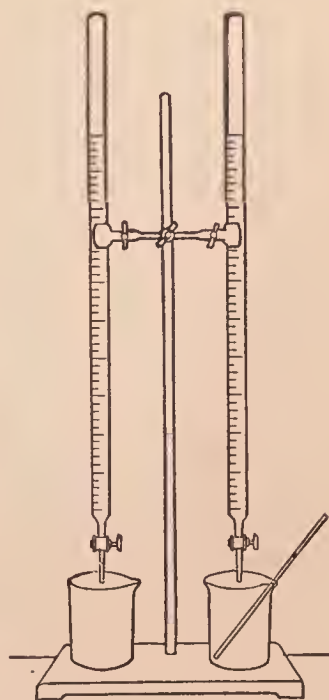

FIG. 42. — Burettes for accurate neutralization



— one with the acid solution and one with the base solution (Fig. 42). Label each burette. Be sure the tip of the burette is free from air bubbles. (To remove air bubbles, open the stopcock slightly, and shake the burette up and down quickly.) Place the waste beaker under each burette in turn and allow the solution to run out slowly until the bottom of the meniscus rests on the 0 line when the eye is on a level with the same line. (See Fig. 43.) Set the waste beaker aside.

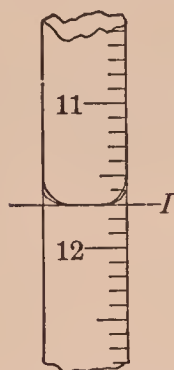

FIG. 43. — Meniscus  
— correct reading  
along line *I*

Put a clean beaker under the base burette and let exactly 15 cc. run into the beaker; enter in I in the RECORD. Remove the beaker, add 2 or 3 drops of phenolphthalein solution, put the beaker under the acid burette, and let the acid solution run in drop by drop, stirring constantly with the

clean rod until the red color (caused by the base) just disappears and the solution becomes colorless (caused by the *very* slight excess of acid). Read the exact volume of acid solution added and enter in I.

#### RECORD

$$\text{I. NaOH sol. } 0 - 15 = 15$$

$$\text{HCl sol. } 0 - \quad = \quad 1 \text{ cc. NaOH sol.} = \text{ cc. HCl sol.}$$

$$\text{II. NaOH sol. } 15 - 30 = 15$$

$$\text{HCl sol. } \quad - \quad = \quad 1 \text{ cc. NaOH sol.} = \text{ cc. HCl sol.}$$

$$\text{III. NaOH sol. } 30 - 45 = 15$$

$$\text{HCl sol. } \quad - \quad = \quad 1 \text{ cc. NaOH sol.} = \text{ cc. HCl sol.}$$

$$\therefore 1 \text{ cc. NaOH sol.} = \text{ cc. HCl sol. (average)}$$

$$1 \text{ cc. of NaOH solution contains} \quad \text{gm. NaOH}$$

$$1 \text{ cc. of HCl solution contains} \quad \text{gm. HCl.}$$

Pour the solution out of this beaker, wash the beaker, and proceed, as before, to neutralize a second 15 cc. of NaOH solution. Enter in II.

Wash the beaker and proceed with a third 15 cc. of NaOH solution. Enter in III.

Calculation. — Our problem is to calculate the number of grams of HCl in 1 cc. of the solution of hydrochloric acid used in this exercise.

(a) First write the equation for the reaction, thus: —

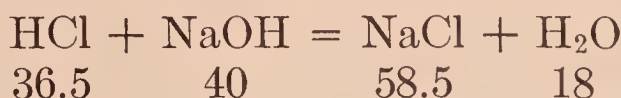

This equation means that 36.5 gm. of HCl are needed to neutralize 40 gm. of NaOH.

(b) Next calculate (from I, II, III, above) the average number of cubic centimeters of hydrochloric acid solution which would be neutralized by 1 cc. of sodium hydroxide solution. For example, suppose you find 1.5 cc. HCl sol. = 1 cc. NaOH sol. (Your result, of course, may be different from this value.)

(c) Find out from the Teacher the concentration of the sodium hydroxide solution. For example, suppose 1 cc. of the given sodium hydroxide solution contains 0.00641 gm. of NaOH.

(d) Now from the equation in (a) we see that 40 gm. of NaOH require 36.5 gm. of HCl. Then the number of grams of HCl required by 0.00641 gm. of NaOH would be found by the proportion

$$40 : 36.5 :: 0.00641 : x \quad x = 0.00585$$

(Your result depends on the concentration of your NaOH solution.) But 0.00585 gm. of HCl would be dissolved in 1.5 cc. of hydrochloric acid (according to our supposition in (b)). Therefore, to find the number of grams of HCl that would be dissolved in 1 cc. of the acid solution, we divide 0.00585 by 1.5, *i.e.*  $0.00585 \div 1.5 = 0.0039$ . Ans. 0.0039 gm. of HCl in 1 cc.

From your results of titration and the known concentration of the NaOH solution, calculate the weight (in grams) of the compound HCl in 1 cc. of the given hydrochloric acid solution. Enter the result in your RECORD.

*If time permits, write a brief account of this exercise in your laboratory notes (in addition to your RECORD), and also draw the apparatus.*

## Exercise 31 — Preparation of Salts

**MATERIALS.** — Calcium, calcium oxide and carbonate, lead oxide; solutions of lead nitrate, sodium sulfate, and sodium hydroxide.

**A. Salts Soluble in Water.** (a) An acid and a metal. Put a small piece of calcium in an evaporating dish, add a little dilute hydrochloric acid, stand the dish on a gauze-covered ring, and heat gently in the hood until the calcium disappears, adding more acid if necessary. Then evaporate the solution to dryness; heat gently toward the end to prevent spattering. Moisten the residue with water, and evaporate again to dryness. Heat the residue until no more fumes of hydrochloric acid are evolved. Let the dish cool, and loosen the solid with a glass rod.

Test small portions of the solid residue for (1) calcium (flame test), and (2) a chloride. Note the results.

(b) An acid and an oxide. Proceed as in (a), using hydrochloric acid and a small piece of calcium oxide. Test the final residue as in (a). Note the results.

(c) An acid and a carbonate. Proceed as in (a), using hydrochloric acid and a small piece of calcium carbonate. Test the final residue as in (a). Note the results.

(d) An acid and a base. Proceed as in **Exercise 29**.

**B. Salts Insoluble in Water.** (a) An acid and a salt. Add 5 cc. of sulfuric acid to 5 cc. of lead nitrate solution. Note the formation of an insoluble salt. Observe its color, fineness, heaviness, and insolubility.

(b) A salt and a salt. Add 5 cc. of sodium sulfate solution to 5 cc. of lead nitrate solution. Note and observe as in (a).

(c) An acid and an oxide. Add 5 gm. of lead oxide to 10 or 15 cc. of dilute hydrochloric acid, heat, let any unchanged solid settle, pour the hot liquid into another test tube, and cool in running water. Note and observe as in (a).

(d) An acid and a carbonate. Proceed as in (c), using lead carbonate. Note and observe as in (a).

**C. Normal Salt.** Put 10 cc. of dilute sulfuric acid in an evaporating dish and neutralize it exactly with sodium hydroxide (see **Exercise 30**). Evaporate to about two-thirds



its volume, let the solution crystallize. The solid product is a normal salt.

**D. Acid Salt.** Proceed as in **C** with the neutralization, then add 10 cc. more of the sulfuric acid, evaporate to about two-thirds its volume, and let it crystallize. The solid product is an acid salt.

*Write a brief account of this exercise in your laboratory notes, giving under each lettered part the name and formula of the salt formed.*

*Write also equations for all the reactions.*

## SUPPLEMENTARY EXERCISES ON ACIDS, BASES, AND SALTS

### Supplementary Exercise 28 — General Properties of Acids

**MATERIALS.** — Sulfuric, hydrochloric, and nitric acids, litmus paper (both colors), magnesium ribbon, sodium carbonate, lime-water.

Fill three test tubes half full of water; add about 5 cc. of dilute sulfuric acid to one, of hydrochloric acid to another, and of nitric acid to the third. Shake the test tubes thoroughly, and label each.

(a) Dip a clean glass rod into each acid successively and *cautiously* taste it. Note the taste.

(b) Dip a clean glass rod into each acid successively and put a drop on both kinds of litmus paper. Note the decided change in color. The change is characteristic of acids.

(c) Pour out the very dilute solutions of the acids and replace the hydrochloric and sulfuric acids with the dilute acid from the stock bottle. Omit the nitric acid. Slip a small piece of magnesium ribbon into each test tube. Note the result. If not conspicuous, warm each gently. Test the most obvious product by holding a lighted match inside of each tube. Note the result.

(d) (1) Fill a test tube half full of dilute sulfuric acid, have ready a lump of sodium carbonate to add to the acid. Dip a glass tube just below the surface of some limewater,

and press the finger down upon the outer end of the tube to hold in the limewater. Lift out the tube, drop the sodium carbonate into the acid, and hold the limewater tube in the escaping gas (Fig. 44). Note the effect on the limewater.

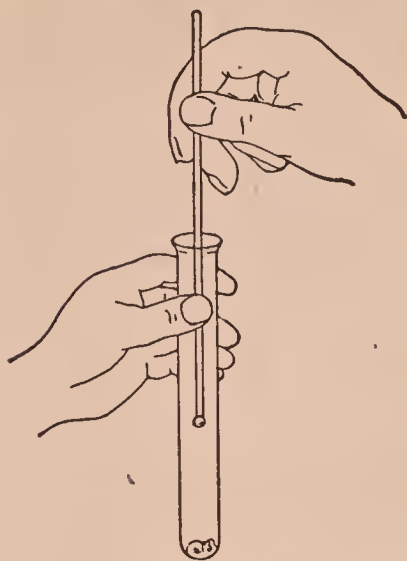

FIG. 44. — Testing for carbon dioxide with a limewater tube

(2) Proceed as in (1) with the other two acids.

*Write in your laboratory notes a summary of the properties of acids.*

*Write also an explanation of the chemical change in (c) and (d).*

### Supplementary Exercise 29 — General Properties of Bases

**MATERIALS.** — Sodium hydroxide and potassium hydroxide solutions, ammonium hydroxide, litmus paper (both colors).

Prepare a very dilute solution of each base as in **Supplementary Exercises 28**.

(a) Cautiously taste each solution by touching to the tip of the tongue a rod moistened with each. Note the result.

(b) Test each solution with litmus paper (both colors). Note the result.

(c) Rub a little of each undiluted solution from the stock bottle between the fingers, and note the feeling.

*Write in your laboratory notes a summary of the properties of bases.*

*Write also a comparison of the corresponding tests for acids.*

### Supplementary Exercise 30 — Two Properties of Many Salts

**MATERIALS.** — Litmus paper (both colors), dilute solutions of chemically pure sodium chloride, potassium nitrate, potassium sulfate, barium chloride, potassium chlorate, potassium bromide, and strontium nitrate.

(a) Test the solutions with litmus paper. Note the result in each case. Compare the litmus reaction of these salts with the reaction of acids and bases.

(b) Dip a clean glass rod into each solution (except barium chloride) successively and cautiously taste it. *Do not swallow the liquid.* Note the taste.

*Write a brief statement in your laboratory notes of these two properties of many salts.*

## IONIZATION AND IONS

### Exercise 32 — Electrolytes and Non-Electrolytes — Teacher's Exercise

**MATERIALS.** — Hydrochloric acid, sodium hydroxide, calcium chloride, sugar, alcohol, glycerin.

**APPARATUS.** — As in Fig. 45. *A* is a jar for the solution, *B* and *C* are electrodes of aluminum which are supported on the top of the jar by a strip of wood. *D* is an electric light bulb which is connected with the wire from the electrode *B* and with one end of the wire *E*. The wire from the electrode *C* and the other end of the wire *E* are connected with a direct street current (reduced), a storage battery, or 4 dry cells.

**OBJECT.** — To find out whether a substance forms a conducting or a non-conducting solution.

Construct and arrange the apparatus as in Fig. 45.

(a) Fill the jar two-thirds full of dilute hydrochloric acid, see that all connections are tight, and turn on the current. Note whether the bulb glows.

(b) Proceed as in (a), using successively solutions of sodium hydroxide, calcium chloride, sugar, alcohol, and glycerin. Clean the electrodes and jar each time. Observe each result.

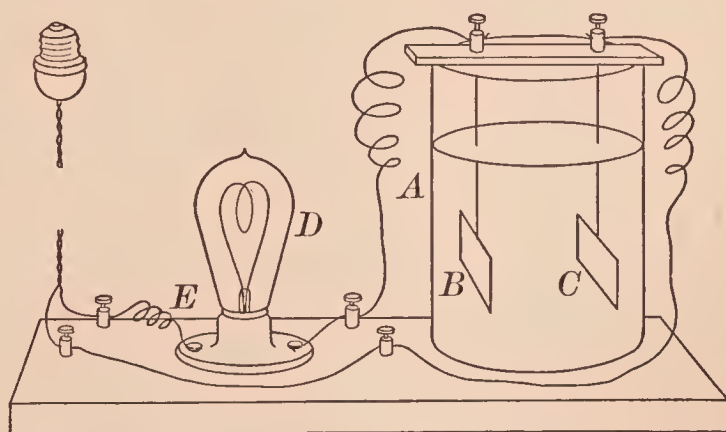

FIG. 45. — Apparatus for showing what solutions conduct electricity



Write a brief account of this exercise in your laboratory notes.

Write also answers to these questions. (1) What substances form solutions which conduct electricity? (2) What substances form non-conducting solutions? (3) What is the name of the classes of substances in (1)?

### Exercise 33 — Electrolysis of Copper Sulfate Solution — Teacher's Exercise

**MATERIALS.** — Copper sulfate solution, joss stick.

**APPARATUS.** — Hofmann apparatus, storage battery or reduced direct current.

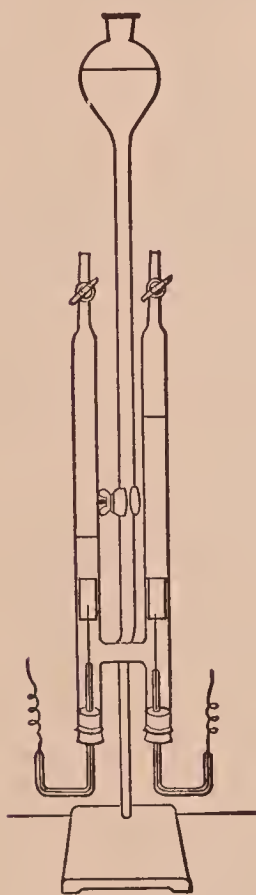

FIG. 46. — Hofmann apparatus for electrolysis

Fill the Hofmann apparatus (Fig. 46) full of copper sulfate solution. Connect with a storage battery or a reduced direct current. Turn on the current and let it run until about 10 cc. of gas collects.

Note at which electrode (anode or cathode) (a) a gas was liberated, and (b) a solid deposited.

Have a glowing joss stick ready, let out a little gas, and test it with the glowing joss stick. Note what the gas is. Also note what the solid is.

Write a short account of this exercise in your laboratory notes.

Write also answers to these questions.

- (1) What ions are in copper sulfate solution?
- (2) To what electrode does each kind of ion migrate?
- (3) What happens when the ions reach the electrodes?
- (4) What secondary action takes place at one electrode?

### Exercise 34 — Reversible Reactions

**MATERIALS.** — Antimony trichloride and sodium hydrogen sulfate ( $\text{NaHSO}_4$ ) solutions.

(a) Pour a little antimony trichloride solution into a test tube three-fourths full of water. Note the precipitate

(antimony oxychloride), especially its color and texture. Shake well. To a portion of the suspended precipitate add a little concentrated hydrochloric acid, drop by drop, shaking constantly, until a definite change occurs. Note the result.

(b) To 10 cc. of concentrated sodium hydrogen sulfate add concentrated hydrochloric acid slowly until a definite change occurs. Note the result.

*Write a brief description of (a) and (b) in your laboratory notes.*

*Write the equation for the reversible reaction in (a) and (b) both in words and in formulas.*

### Exercise 35 — Colored and Colorless Ions — Teacher's Exercise

**MATERIALS.** — Solutions (dilute) of copper sulfate, copper nitrate, copper bromide, nickel chloride, nickel sulfate, cobalt chloride, cobalt nitrate, potassium dichromate, ammonium dichromate, sodium dichromate, potassium chromate, potassium permanganate.

(a) Observe the color of the copper solutions. Conclude to what ion the color is due. Give its ionic name and formula.

(b) As in (a) with the nickel, etc., solutions.

*Copy this table in your laboratory notes and fill in the items:*

#### COLORED AND COLORLESS IONS

CATIONS			ANIONS		
Name	Formula	Color	Name	Formula	Color
1			1		
2			2		
3			3		
etc.			etc.		

## SUPPLEMENTARY EXERCISES ON IONIZATION AND IONS

### Supplementary Exercise 31 — Electrolysis of Copper Sulfate Solution (Short Method) — Teacher's Exercise

**MATERIAL.** — Dilute copper sulfate solution.

**APPARATUS.** — Small battery jar (or beaker), two electrodes (pieces of electric light carbon) and connection wires, storage battery (or other source of direct electric current).

Fill the battery jar about two-thirds full of dilute copper sulfate solution. Wind the end of a piece of the wire around one end of each electrode and hang the electrodes in the solution by bending the wire over the edge of the jar (or supporting them by a strip of wood which rests across the top of the jar). Connect the ends of the wires with the storage battery (or other source of direct electric current).

Before turning on the current (or making the final connection), examine each electrode and note the absence of a deposit. Turn on the current and observe at which electrode bubbles of gas form. Let the current run about ten minutes, and then examine each electrode. Compare with their appearance before the electrolysis took place. Note upon which electrode (anode or cathode) there is a deposit. Note the deposit.

*Write in your laboratory notes a brief account of the electrolysis of copper sulfate in terms of the ionization theory, using a sketch of the apparatus in your account.*

### Supplementary Exercise 32 — Electrolysis of Sodium Sulfate Solution — Teacher's Exercise

**MATERIALS.** — Sodium sulfate solution, neutral litmus solution, joss stick, wax taper.

Fill the Hofmann apparatus (Fig. 46) full of sodium sulfate solution colored with neutral litmus solution. Proceed as in **Exercise 33**. Let the current run until the smaller volume of gas measures about 10 cc. Observe the color of the solution in each tube; also the relative quantity of gas. Test the gases as in **Exercise 33**. Note the result.



Write in your laboratory notes an interpretation of the electrolysis of sodium sulfate by the theory of ionization.

Write also answers to these questions. (1) What is the name of each gas? (2) At which electrode was each gas liberated? (3) Why was the color changed in each tube?

### Supplementary Exercise 33 — Chemical Behavior of Solutions of Acids, Bases, and Salts (Testing for Ions)

**MATERIALS.** — For (a) hydrochloric acid, solutions of chlorides of barium, calcium, sodium; for (b) sulfuric acid, solutions of sulfates of copper, sodium, zinc; for (c) solutions of hydroxides of sodium and potassium; also solutions of silver nitrate, silver sulfate, barium chloride, barium nitrate, and zinc sulfate.

(a) (1) Test separately a dilute solution of the substances enumerated in (a) by adding to each a few drops of silver nitrate solution. Note each result. Conclude what ion is in each tested solution. Enter each result in the table (see below) in your laboratory notes.

(2) Proceed as in (1), using silver sulfate solution. Note and make the entries, as in (1).

(b) (1) Proceed as in (a) (1), using barium chloride solution and the solutions enumerated in (b). Note, conclude, and enter the results in the table.

(2) Proceed as in (1), using barium nitrate solution in place of barium chloride. Note, conclude, and enter as before.

(c) Add (1) a few drops of the solutions of hydroxides enumerated in (c) to zinc sulfate solution and then (2) an excess of each hydroxide. Note, conclude, and enter as before.

Write the results of this exercise in tabular form in your laboratory notes, thus:—

SUBSTANCE	RESULT	CONCLUSION

## Optional Exercises

1. What ion is common to solutions of hydrochloric acid and chlorides? Of sulfuric acid and sulfates?
2. Explain the general result in (a) and in (b) in terms of the theory of ionization. Also the results in (c) (1).
3. What ion is common to all (a) barium salts and (b) silver salts?
4. What ion other than potassium ion is in a solution of (a) potassium chloride, (b) potassium chlorate, and (c) potassium perchlorate?
5. What ion is in solutions of (a) all acids and (b) all bases?
6. Make a list of the acids, bases, and salts used in this experiment and their corresponding ions, indicating the substances and ions by name and formula.

### Supplementary Exercise 34 — Hydrolysis of Certain Salts

**MATERIALS.** — Solutions of sodium carbonate, ferric chloride, aluminum sulfate, copper sulfate, zinc chloride.

Test a solution of each salt with litmus paper (both kinds), and note the result.

*Write in your laboratory notes the effect of each dissolved salt on litmus.*

*Write also answers to (1) What is hydrolysis? (2) What classes of salts undergo hydrolysis?*

## AMMONIA

### ★Exercise 36 — Preparation and Properties of Ammonia

**MATERIALS.** — Lime (calcium oxide), ammonium chloride, concentrated hydrochloric acid.

**APPARATUS.** — As in Fig. 47. The test tube *A* is provided with a one-hole rubber stopper to which is fitted a glass tube *B* which reaches well up into the bottle *C*; 3 bottles, pneumatic trough filled as usual. Optional forms of apparatus (as in Fig. 48) may be used.

**Caution.** — Do not inhale ammonia (gas). Perform this experiment in the hood.

**I. Preparation.** — Weigh 10 gm. of lime and 10 gm. of ammonium chloride, and mix them thoroughly on a piece of paper. Slip the mixture into *A* (Fig. 47), and add a little water, thereby transforming the calcium oxide into calcium hydroxide. Mix well. Quickly insert the stopper with its tube, and clamp *A* as in Fig. 47. Stand the bottle *C* over the tube *B*.

If the simpler apparatus (Fig. 48) is used, put about 5 gm. of each ingredient, together with the water, in the lower test tube. Heat this tube and collect the gas in the upper tube.

Heat *A* gently with a low flame. Begin to heat the test tube near the end and slowly work forward toward the delivery tube. Ammonia (gas) will pass up into the bottle, which should be removed, when full, covered tightly with a glass plate or filter paper, and stood mouth downward on the desk. A piece of moist red litmus paper held near the mouth will show (by change in color) when the bottle is full. *Do not smell at the mouth of the bottle.* Collect two bottles of the gas.

**II. Properties.** — (a) Test the gas in one bottle, or test tube, with a blazing joss stick. Observe the result.

(b) Invert the same bottle in the pneumatic trough, and shake it vigorously, taking care to keep the mouth under water. Observe the change inside the bottle. Cover the mouth of the bottle with the hand or filter paper, invert, and stand upright on the desk. Test the contents of the bottle with litmus paper (both colors), and note the result.

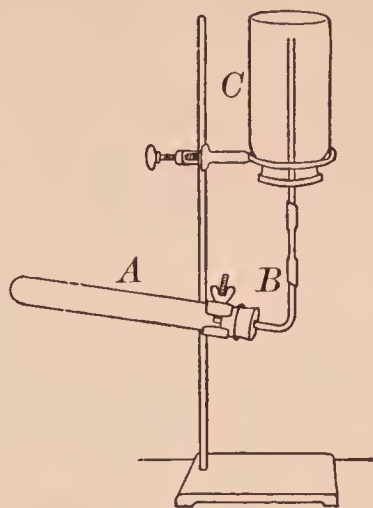

FIG. 47. — Apparatus for preparing ammonia

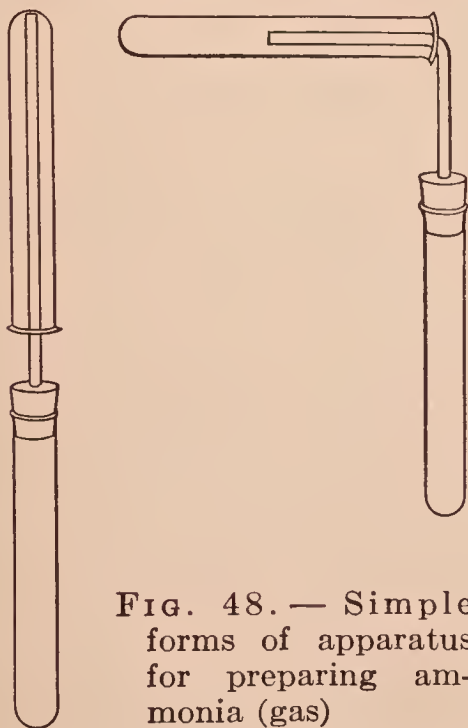

FIG. 48. — Simple forms of apparatus for preparing ammonia (gas)

invert, and stand upright on the desk. Test the contents of the bottle with litmus paper (both colors), and note the result.



(c) Pour a few drops of concentrated hydrochloric acid into an *empty*, warm, dry bottle. Rotate the bottle until the inside is well moistened with the acid. Cover it with a glass plate, invert it, and stand it upon a covered bottle of ammonia (gas). Remove both plates at once, and hold the bottles together by grasping them firmly about their necks. Observe the result, especially the evidence of the chemical action and the white substance.

*Write in your laboratory notes (1) the equation for I, (2) a summary of the properties of ammonia based on II, (3) a statement of other observed properties of ammonia, e.g. color, odor, specific gravity, behavior with litmus, and (4) the test for ammonia.*

*Answer also (5) What is a test for ammonium compounds? (6) What is the equation for II (c)? (7) What (besides the product) is the evidence of chemical action in II (c)?*

## SUPPLEMENTARY EXERCISE ON AMMONIA

### Supplementary Exercise 35 — Preparation of Ammonia (Gas) from Various Substances

**MATERIALS.** — Gelatin, soda-lime, litmus paper, concentrated hydrochloric acid, substances enumerated in (b), ammonium sulfate, ammonium nitrate, sodium hydroxide solution.

(a) Mix a little gelatin and soda-lime on a piece of paper, slip the mixture into a test tube, attach a test tube holder, heat, and test the escaping gas with moist red litmus paper, or by a glass rod moistened with concentrated hydrochloric acid. Note the result.

(b) Repeat (a), using soda-lime with hair, feather, leather scraps, or pieces of horn. Observe the result.

(c) Dissolve a little ammonium chloride in water, add a little sodium hydroxide solution, warm gently, and test (cautiously) the liberated gas by its odor. Note the result.

(d) Repeat (c), using ammonium sulfate and sodium hydroxide solution. Note the result.

(e) Proceed as in (d), using ammonium nitrate. Note the result.

Write in your laboratory notes (1) the result of each lettered part of this exercise, and (2) the equations of (c), (d), (e).

## NITRIC ACID — NITROGEN OXIDES

### Exercise 37 — Preparation of Nitric Acid — Teacher's Exercise

MATERIALS. — Sodium nitrate, concentrated sulfuric acid.

APPARATUS. — Glass stoppered retort, etc., as in Fig. 49.

**Caution.** — Concentrated nitric acid and sulfuric acid are very corrosive. Do not spill them on the flesh or the clothing. Perform this exercise very carefully.

Weigh 20 gm. of sodium nitrate and slip it into the retort through the tubulure (opening where the stopper goes). Fill the bottle nearly full of water. Put a large empty test tube into the bottle, insert the neck of the retort into the test tube, and clamp the retort (upon the iron gauze) to the stand as shown in Fig. 49. Stand

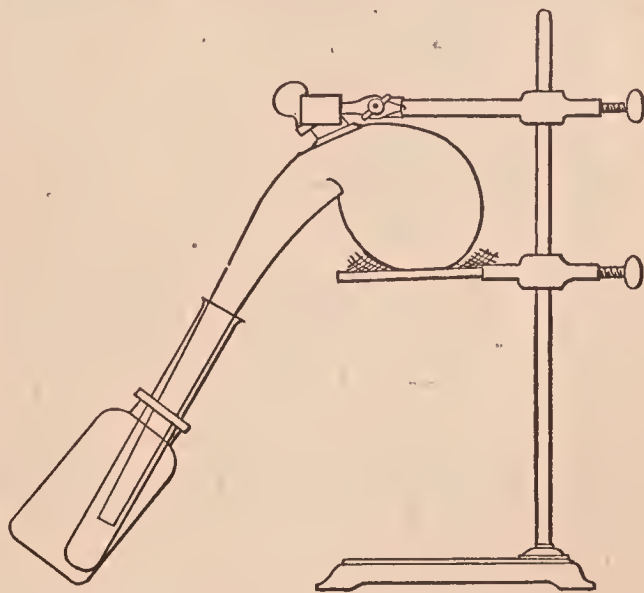

FIG. 49. — Apparatus for preparing nitric acid in the laboratory

a funnel in the tubulure of the retort so that the end is well inside the bulb, and pour 20 cc. of concentrated sulfuric acid through the funnel. Remove the funnel and insert the stopper of the retort tightly.

Heat the retort gently as long as any nitric acid runs down the neck into the test tube. Then unclamp the retort and remove the test tube carefully, taking great care not to get any nitric acid on the hands.

NOTE. — Allow the contents of the retort to cool, add a little water, boil until the solid in the bulb is reduced to a small bulk or dissolved, and pour the contents into a waste jar in the hood.

*Write a brief account of this exercise in your laboratory notes.*

### ★Exercise 38 — Properties of Nitric Acid

MATERIALS. — Concentrated nitric acid, quill toothpick, sulfur, barium chloride solution, zinc, copper, magnesium.

(a) Observe the color of the concentrated nitric acid prepared in **Exercise 37**. Compare with the specimen of concentrated nitric acid in the bottle on the side shelf.

(b) Hold a piece of wet filter paper at the mouth of a test tube of concentrated nitric acid. Observe the result.

(c) Repeat (b), using a piece of filter paper moistened with ammonium hydroxide. Note the product.

(d) Pour 5 cc. of concentrated nitric acid *very carefully* into a test tube, drop in a piece of a quill toothpick, and observe any change in the color of the quill. Heat very gently, and observe the effect on the quill. Note the final result.

(e) Put about 1 gm. of sulfur in a test tube, add a little water and then very carefully 5 cc. of concentrated nitric acid. Attach the test tube holder, and boil cautiously — in the hood — for a few minutes. Add 10 to 15 cc. of water, filter the solution, if it is not clear, and test the filtrate for a sulfate by adding barium chloride solution. Note the result.

(f) Stand three test tubes in the test tube rack, put a piece of zinc into one, copper into another, and magnesium ribbon (rolled into a ball) into the third. Add a little concentrated nitric acid to each test tube. Observe the result. Test the gaseous product for hydrogen, and note the result. (Compare **Exercise 39 II**.) Note also the color of the copper solution.

*Write answers to these questions in your laboratory notes.*

- (1) *What property of nitric acid was shown by (a)? By (b)? By (c)? By (d)? By (e)?*
- (2) *What is the result of (b)?*
- (3) *How does the action in (f) compare with that of hydrochloric acid and sulfuric acid?*



## ★Exercise 39 — Interaction of Nitric Acid and Copper (and Study of Nitric Oxide and Nitrogen Dioxide)

**MATERIALS.** — Copper (borings or fine pieces of sheet metal), concentrated nitric acid, piece of copper wire (15 cm. or 6 in. long).

**APPARATUS.** — As in Fig. 50.

**I. Preparation (Nitric Oxide).** — Put 10 gm. of copper in the bottle *A* and arrange the apparatus to collect the gas over water (Fig. 50). Fill three bottles with water, and invert one of them in the trough. Have the others ready.

Dilute 25 cc. of concentrated nitric acid with an equal volume of water, and introduce just enough of this diluted acid through the dropping tube to cause gentle chemical action. If the action becomes

too vigorous, add water immediately through the dropping tube; if too weak, then add just enough of the diluted nitric acid to cause gentle action.

Collect three bottles of the nitric oxide, remove, invert and cover them quickly with glass plates or *tightly* with moist filter paper.

**II. Properties.** — (a) Observe the general properties of nitric oxide while covered.

(b) Uncover a bottle. Observe the result. The brown gas is nitrogen dioxide.

(c) Uncover another bottle, let the brown gas form, then pour in about 25 cc. of water, cover at once with the hand and shake vigorously, still keeping the bottle covered. Note whether the brown gas is soluble or insoluble in the water.

(d) With the third bottle, determine whether the gases will burn or support combustion. A convenient flame is a burning match fastened to a copper wire. (1) Uncover a

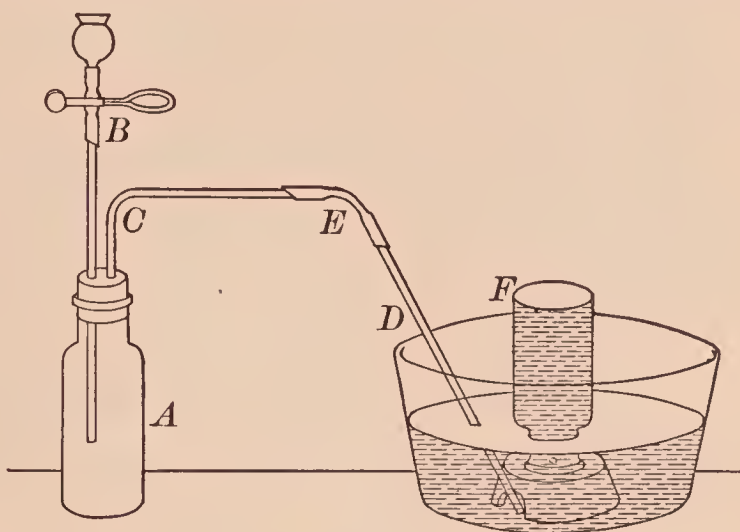

FIG. 50. — Apparatus for preparing nitric oxide

bottle, quickly plunge the lighted match to the bottom of the bottle, and immediately replace the glass plate. Observe the result. (2) Remove the glass plate, let considerable brown gas form, lower a burning match into the brown gas, and observe the result.

**III. Copper Nitrate.** — Filter the contents of the bottle A and test portions of the filtrate for (1) copper by adding a clean iron nail and noting the deposit, and (2) a nitrate as in **Exercise 40**. Note each result.

*Write in your laboratory notes a summary of the properties of nitric oxide and nitrogen dioxide.*

*Write also answers to these questions. (1) What is the general chemical relation of the two gases to each other? (2) What is the equation for I and for II (b)?*

### **★Exercise 40 — Test for Nitric Acid and Nitrates**

**MATERIALS.** — Ferrous sulfate, sodium nitrate.

(a) To 10 cc. of water add 1 or 2 cc. of concentrated nitric acid, and shake. Prepare a ferrous sulfate solution by washing several crystals in cold water and dissolving a clean crystal in 10 cc. of cold water.



**FIG. 51.** — Test for nitric acid and nitrates

Pour this solution into the nitric acid. Mix well. Incline the test tube and pour about 5 cc. of concentrated sulfuric acid down the inside of the tube. The sulfuric acid will sink through the other liquid. At the surface where the two solutions meet, a brown or black layer will appear (Fig. 51). Its formation serves as a test for nitric acid.

(b) Proceed as in (a), using a concentrated solution of sodium nitrate instead of nitric acid. Note the result and compare with (a).

*Write the test for nitric acid and a nitrate in your laboratory notes.*

## SUPPLEMENTARY EXERCISE ON NITROGEN OXIDES

### Supplementary Exercise 36 — Preparation and Properties of Nitrous Oxide — Teacher's Exercise

**MATERIALS.** — Ammonium nitrate, wad of iron thread, copper wire, sulfur, joss stick.

**APPARATUS.** — As in Fig. 52.

Put 10 gm. of ammonium nitrate in the flask *A*. Arrange the apparatus as shown in Fig. 52. The large test tube *B* remains empty. Be sure the apparatus does not leak.

**I. Preparation.** — Heat the flask gently with a low flame. The ammonium nitrate melts at first and soon appears to boil, owing to the decomposition of the salt and escape of nitrous oxide. Regulate the heat so that the evolution of nitrous oxide is slow. Notice the liquid which collects in *B*.

Collect three bottles of nitrous oxide, covering each with a piece

of filter paper as soon as removed from the trough. When the last bottle has been collected and covered, remove the end of the delivery tube from the trough.

**II. Properties.** — (a) Allow a bottle to remain uncovered for a few seconds. Note the difference between nitrous oxide and nitric oxide.

(b) Thrust a glowing joss stick into the same bottle of gas. Observe the result.

(c) Put a piece of sulfur in a deflagrating spoon, light it, and lower the burning sulfur at once into another bottle of gas. Observe the result.

(d) Twist one end of the copper wire around a wad of iron

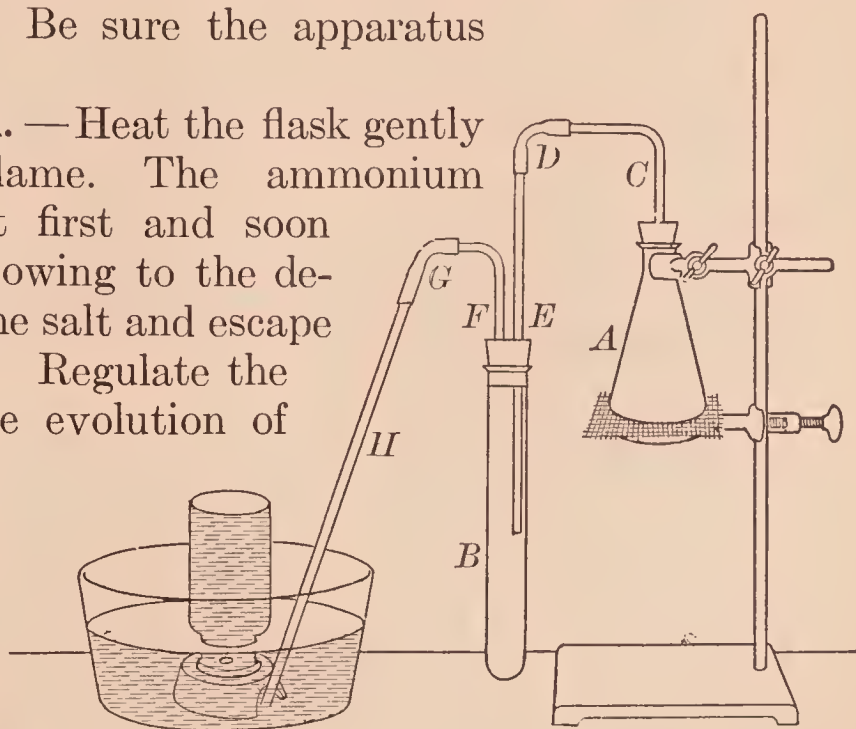

FIG. 52. — Apparatus for preparing nitrous oxide



thread. Heat the edge of the wad an instant in the flame and then lower it quickly into a bottle of the gas. Observe the result.

*Write answers to these questions in your laboratory notes.*  
(1) *What are the conspicuous properties of nitrous oxide?*  
(2) *What is the equation for I?* (3) *How could you distinguish nitrous oxide from (a) the other oxides of nitrogen, (b) air, (c) oxygen, (d) hydrogen, (e) nitrogen, (f) carbon dioxide?*

## MOLECULAR WEIGHTS

### Exercise 41 — Weight of 22.4 Liters of Oxygen

**MATERIALS.** — Potassium chlorate, manganese dioxide, calcium chloride, glass wool or shredded asbestos. The potassium chlorate and manganese dioxide should be powdered and mixed in equal proportions, and then dried for an hour or more by heating in an oven to 110° C.

**APPARATUS.** — As in Fig. 53. *A* is a test tube attached to the bent tube *F* by a rubber stopper. *B* is a large bottle (2500 cc.) to be filled with water; it is provided with a two-hole rubber stopper, through which pass *F* and *C*, the latter being connected with a rubber tube *C'* to which is attached the short glass tube *G*. A Hofmann screw is attached to the rubber tube at the point *E*. Another bottle (2500 cc.) *D* serves to catch the water forced over from *B* through *CC'* by the oxygen generated in *A*. The hook *S* of aluminum wire permits *A* to be hung from the balance beam in weighing. Thermometer, barometer, balance, scales, weights.

**NOTE.** — This exercise may be postponed until the pupil has acquired more experience in the laboratory.

**OBJECT.** — To find the weight of a certain volume of oxygen, reduce this volume to standard conditions, and calculate the weight of 1 liter of oxygen.

Copy the form of **RECORD**, as given below, in your laboratory notes. Enter all weights and volumes in the proper place as soon as the weighing and measuring are done.

Fill the space 1 in *A* with the dried mixture of equal weights of powdered manganese dioxide and powdered potassium

chlorate (Fig. 53). Push glass wool, or asbestos (the latter should be previously ignited to a red heat), into the space 2 in *A*. Put small lumps of calcium chloride into 3 and glass wool into 4. Push the stopper well into the test tube. Wipe *A* with soft paper. Weigh *AF* accurately on the balance and enter the weight in the proper place in the RECORD. Weigh the empty, dry, clean bottle *D* to a decigram on the scales, and enter the weight.

Fill *B* with water nearly to the neck. Fill *CC'* with water and tighten the Hofmann screw *E* to prevent the water from running out. Insert

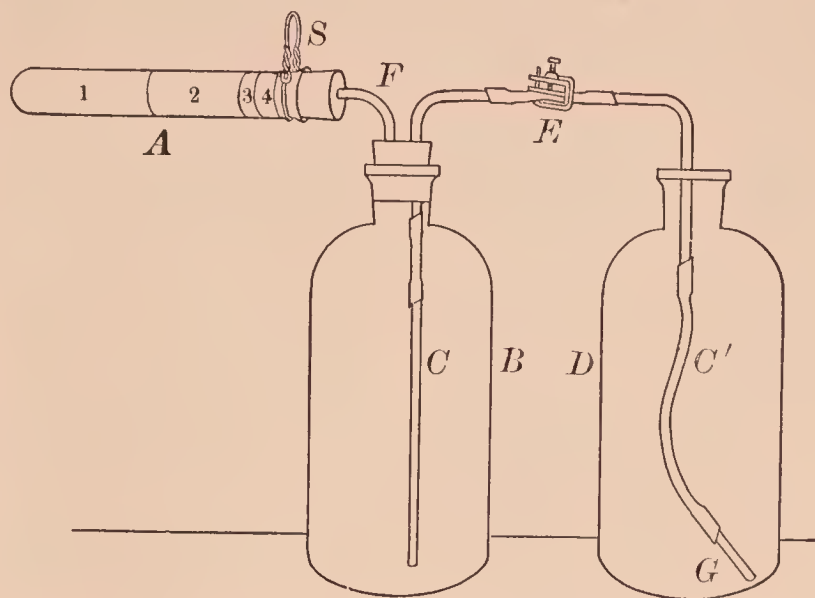

FIG. 53. — Apparatus for finding the weight of 22.4 liters of oxygen

*F* into the stopper of *B*. Push the stopper into the bottle, slowly at first, then hard; if water rises in *F*, loosen the screw at *E* slightly, remove *A*, and blow gently into *F* to force the water back into *B*. When properly adjusted, the water should be in *B* and *CC'* but not in *F*. Replace *A*, taking care not to crush the thin glass by pushing it too hard upon its stopper. *Open the screw E*. If the apparatus is tight, little or no water will flow out. It should be adjusted until air tight. *Leave the screw E open*.

Heat *A* gently with a low flame, keeping the flame back of the space 2. The liberated oxygen will force the water from *B* into *D*. Heat *A* just hot enough to cause a gentle flow of water into *D*. When *B* is about half empty, stop heating. While *A* is cooling, stand a thermometer in *D*; also read the barometer and enter the reading. When *A* is cold, raise *B* until the water is at the same level in *B* and *D*, pinch *C'* tight and remove it from *D*. Read and remove the thermometer, and enter the reading.

Dry *D* on the outside, if necessary, and then weigh it on the scales; enter the weight. The gain in weight (in grams) of *D* equals the volume of oxygen liberated (since 1 gm. of water = 1 cc.).

Weigh *AF* on the balance; enter the weight. Its loss in weight is the weight of the oxygen that passed into *B*.

### RECORD

Weight of tube <i>AF</i> before heating . . . . .	gm.
Weight of tube <i>AF</i> after heating . . . . .	_____ gm.
Weight of oxygen ( <i>W</i> ) . . . . .	gm.
Weight of bottle <i>D</i> and water . . . . .	gm.
Weight of bottle <i>D</i> empty . . . . .	_____ gm.
Weight of water . . . . .	gm.
Volume of water . . . . .	cc.
Observed volume of oxygen ( <i>V'</i> ) . . . . .	cc.
Temperature ( <i>t</i> ) . . . . .	°C.
Pressure read on barometer ( <i>P'</i> ) . . . . .	mm.
Pressure caused by water vapor ( <i>a</i> ) . . . . .	_____ mm.
Corrected pressure . . . . .	mm.
Corrected volume of dry oxygen ( <i>V</i> ) . . . . .	cc.
Corrected volume of dry oxygen in liters ( <i>VL</i> ) . . . . .	l.
Weight of 1 liter of oxygen . . . . .	gm.
Weight of 22.4 liters of oxygen . . . . .	gm.

Correct the observed volume (*V'*) of oxygen for temperature (*t*), pressure (*P'*), and pressure of water vapor (*a*). That is, reduce the observed volume to the volume (*V*) it would occupy, if it were at 0° C., 760 mm., and in the dry state (*i.e.* free from water vapor).

Water vapor exerts a pressure. Hence the pressure for which the observed volume (*V'*) must be corrected is the observed pressure (*P'*) minus the pressure (*a*) due to the water vapor in the gas. The complete correction is made by this formula: —

$$V = V' \times \frac{273}{273 + t} \times \frac{P' - a}{760}$$



The values for  $a$  at different temperatures are given in the APPENDIX, § 1.

Calculation of the weight of 1 liter of oxygen. Since 1 liter contains 1000 cubic centimeters, then  $V \div 1000$  is the actual volume of liberated oxygen expressed in liters ( $Vl$ ). The weight of liberated oxygen ( $W$ ) is found by subtracting the weight of  $AF$  after heating from its weight before heating. The weight of 1 liter of oxygen in grams is found by dividing the weight of liberated oxygen by its volume, *i.e.*  $W \div Vl =$  the weight of 1 liter of oxygen. Multiply this weight by 22.4. Complete the entries in the RECORD in your laboratory notes.

## SULFUR

### ★Exercise 42 — Different Forms of Sulfur

MATERIALS. — Roll sulfur, carbon disulfide.

APPARATUS. — Lens.

**I. Orthorhombic (or Rhombic).** — Put about 2 gm. of coarsely powdered roll sulfur in a test tube and add about 5 cc. of carbon disulfide — remember to keep the carbon disulfide away from flames. Shake until most of the sulfur is dissolved, then pour some of the clear solution upon a glass plate to crystallize. Allow the liquid to evaporate; watch the crystallization. Examine the crystals with the eye and with a lens. Note the color, luster, and shape. Draw the best shaped one in your laboratory notes.

**II. Monoclinic.** — Fix a folded filter paper firmly in a funnel, and place the funnel in a test tube which stands in a rack. Fill a test tube two-thirds full of roll sulfur, heat it at first throughout its length, and gradually increase the heat until all the sulfur is melted. Then quickly pour it upon the filter paper. Let it cool until crystals appear just below the surface, and then pour out the remaining melted sulfur at once into a dish of water.

Remove the paper and adhering sulfur, and cut, or break, open the cone of crystallized sulfur. Observe the crystals, especially the shape, size, color, luster, and brittleness. Allow

the best crystals to remain undisturbed for a day or two; then examine again, and note any marked changes.

**III. Amorphous (or Plastic).** — Put a few pieces of roll sulfur in a test tube. Heat carefully until the sulfur boils, and then quickly pour the molten sulfur into a dish of cold water. This is the plastic variety of amorphous sulfur. Note its properties.

Preserve it and examine after twenty-four hours. Note its properties and compare them with those previously observed.

*Write in your laboratory notes a description of each kind of sulfur.*

### **★Exercise 43 — Preparation and Properties of Sulfur Dioxide (Short Method)**

**MATERIALS.** — Sulfur, joss stick, litmus paper, potassium permanganate solution (dilute), bright colored paper.

**APPARATUS.** — Bottle fitted with cork.

**Caution.** — Perform this experiment in the hood.

**I. Preparation.** — Fill a deflagrating spoon with sulfur, set it afire, and lower the spoon into a bottle. In a minute or two, remove the spoon, and cover the bottle with a glass plate or (tightly) with a piece of filter paper. In the same way prepare and cover two more bottles of sulfur dioxide.

**II. Properties.** — (a) *Cautiously* note the odor. After the smoke (which is not sulfur dioxide) has settled, note whether the gas has any color. Hold a blazing joss stick or a burning match in the bottle and note whether the gas burns or supports combustion.

(b) Stand the second bottle of gas mouth downward in a vessel of water (*e.g.* pneumatic trough). Shake vigorously, still keeping the mouth submerged. Observe the result. Slip a piece of filter paper under the mouth of the bottle, remove, invert, and test the liquid with litmus paper. Note the result. Save for (c).

(c) Pour a few drops of very dilute potassium permanganate solution into the bottle saved from (b), and shake well. Com-

pare the color of the two liquids. If the result is not satisfactory, repeat, and use a bottle full of sulfur dioxide to which only 5 cc. of water has been added.

(d) Moisten a piece of bright colored paper, put it in the third bottle of sulfur dioxide, and insert the cork. Observe any change in color. (If not decisive, try other kinds of paper.)

*Write answers to these questions in your laboratory notes.*

(1) *What is the chemical equation for I?* (2) *What four physical properties of sulfur dioxide are shown by II (a), (b)?* (3) *What chemical property by II (a)?* (4) *What acid was formed in II (b)?* (5) *How would you explain the chemical change in II (c), (d)?*

#### Exercise 44 — Preparation and Properties of Sulfur Dioxide and Sulfurous Acid (Long Method) — Teacher's Exercise

**MATERIALS.** — Sodium sulfite, dilute sulfuric acid, litmus paper, joss stick, colored flower, dilute potassium permanganate solution and barium chloride solution.

**APPARATUS.** — As in Fig. 54.

**Caution.** — Perform this exercise in the hood.

**I. Preparation.** — (a) **Sulfur Dioxide.** — Put about 10 gm. of sodium sulfite in the flask, and insert the stopper with its tubes. Adjust the apparatus as shown in Fig. 54. Fill the cup with dilute sulfuric acid, press the pinch-clamp a little, and let the acid flow *drop by drop* upon the sodium sulfite. Sulfur dioxide is evolved and passes into the bottle, which should be removed when full, as previously described. Warm gently, if the action slackens. Moist blue litmus paper held for an instant at the mouth of the bottle will show (by change in color) when the latter is full. Collect two

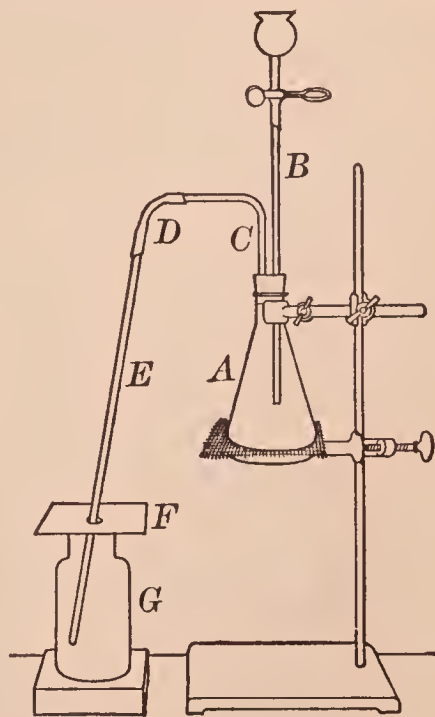

FIG. 54. — Apparatus for preparing sulfur dioxide and sulfurous acid



bottles of gas, cover each tightly with a piece of filter paper or a glass plate, and set aside until needed for II (a), etc.

(b) **Sulfurous Acid.** — As soon as the second bottle of gas has been removed and covered, put in its place a bottle one-fourth full of water. Adjust its height (if necessary) by wooden blocks, so that the end of the delivery tube is just above the surface of the water. Continue to add the acid and to heat at intervals. Shake the bottle occasionally. When II (a), etc., have been done, proceed with this solution as in III (a), etc.

**II. Properties of Sulfur Dioxide Gas.** — Proceed as in Exercise 43 II (a), (b), (c), (d).

**III. Properties of Sulfurous Acid.** — (a) Observe the odor and the taste *cautiously*.

(b) Apply the litmus test, and note the result.

(c) Drop a short piece of magnesium ribbon into 10 cc. of the solution. Warm slightly, if there is no action. Note the liberation of a gas.

(d) Add a few drops of dilute potassium permanganate solution to 5 cc. of sulfurous acid and shake. Observe the result.

(e) Optional. Put about 10 cc. of sulfurous acid in an evaporating dish, support the dish on a gauze-covered ring attached to an iron stand, heat in the hood, and note the odor of the liberated gas. Blow the gas out of the dish frequently, and then smell of the liquid. Boil until most of the liquid is evaporated, and test the remainder with litmus paper. Note the final effect of heat on sulfurous acid.

(f) Optional. Put 10 cc. of sulfurous acid into a test tube, cover loosely, and let it stand exposed to the air for a day or two. Add 10 cc. of water, boil for a minute or two, and test the solution for  $\text{SO}_4$ -ions by adding a few drops of barium chloride solution. Note the result.

(g) Put 10 cc. of sulfurous acid in a test tube, add 2 cc. of concentrated nitric acid, and boil carefully for a minute or two. Add about 10 cc. of water, shake, and test for sulfate ions, as in (f). Note the result.

*Write a brief account of I in your laboratory notes.*

*Write also answers to the questions at the end of Exercise 43.*

Write also answers to these questions. (1) What is the chemical equation for I (a)? (2) For I (b)? (3) What do III (a) and (e) show about the stability of sulfurous acid? (4) How would you explain III (d), (f), (g) in terms of oxidation and reduction? (5) Is the test for  $\text{SO}_4$ -ions in III (f), (g) positive or negative? Explain.

### \*Exercise 45 — Properties of Sulfuric Acid

**MATERIALS.** — Concentrated sulfuric acid, thin stick of wood, sugar.  
**APPARATUS.** — Graduated cylinder (100 cc.) and hydrometer for heavy liquids (optional).

**Caution.** — Concentrated sulfuric acid is a corrosive liquid. Do not spill it on the flesh or clothing.

(a) Weigh (on the scales) a 25 cc. graduated cylinder, pour in concentrated sulfuric acid to a convenient height (e.g. 20 cc.), and weigh again. Read the exact volume of the acid. From the weight and volume of the acid, calculate its specific gravity by dividing the weight (in grams) by the volume (in cubic centimeters). Copy this form in your laboratory notes and complete the calculation: —

$$x = \text{Vol. of acid} = \quad \text{cc.}$$

$$y = \text{Wt. of acid} = \quad \text{gm.}$$

$$\text{Specific gravity} = y \div x = \quad . \quad \text{Ans.}$$

(b) Optional. Find the specific gravity of a sample of the same acid by reading the hydrometer which floats in the acid (Fig. 55). (This apparatus should be arranged for the class by the Teacher.) Compare with the result in (a).

(c) *Care.* Stand a test tube in the rack. Add 10 cc. of water. Pour 10 cc. of concentrated sulfuric acid into a graduated cylinder and then slowly add the acid to the water. Stir with a glass rod, and observe at once the change in temperature by touching the tube with the hand. Save the solution for (d) and (e).

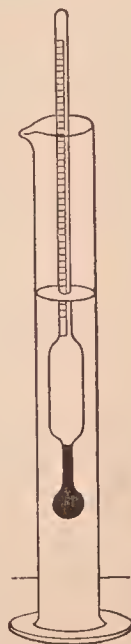

FIG. 55. — Finding the specific gravity of sulfuric acid with the hydrometer

(d) Dip a glass rod into the sulfuric acid from (c) and write some letters or figures on a sheet of paper. Move the paper back and forth slowly above a low flame, taking care not to set fire to the paper. As the water evaporates, the dilute acid becomes concentrated. Observe the effect on the paper. (Paper is largely a compound of carbon, hydrogen, and oxygen, and the hydrogen and oxygen are present in the proportion to form water.)

(e) Warm the acid in the test tube saved from (c), stand a stick of wood in the acid, and allow it to remain for fifteen minutes or more. Then remove the stick and wash off the acid. Note the change in the wood.

(f) Put 5 gm. of sugar in an evaporating dish, add just enough warm water to make a thick sirup, stir, and stand the dish on a block of wood (or in the sink). Cautiously pour 5 or 10 cc. of concentrated sulfuric acid upon the liquid. Stand back and observe the result.

*Write answers to these questions in your laboratory notes.*

(1) *What is the specific gravity of the sample of concentrated sulfuric acid you used?* (2) *How would you interpret the conspicuous result in (d), (e), (f)?* (3) *What does (c) show about the thermal effect of mixing sulfuric acid and water?*

### ★Exercise 46 — Tests for Sulfuric Acid, Sulfates, and $\text{SO}_4$ -ions

MATERIALS. — Sulfuric acid, sodium sulfate, barium chloride solution.

(a) Sulfuric Acid. Devise a test for (1) concentrated and (2) dilute sulfuric acid from **Exercise 45**.

(b) Sulfuric Acid and Soluble Sulfates, *i.e.* solutions containing  $\text{SO}_4$ -ions. — Add barium chloride solution to the solution of the acid or the sulfate. If a fine, white insoluble precipitate (barium sulfate) is formed, the original solution contained  $\text{SO}_4$ -ions.

NOTE. — To test for an insoluble sulfate, such as barium or calcium sulfate, proceed as in **Exercise 53 B (b)**.

*Write in your laboratory notes the test devised for (a) and the statement of the test for  $\text{SO}_4$ -ions, including the ionic equation.*



## ★Exercise 47 — Preparation and Properties of Hydrogen Sulfide (Short Method)

**MATERIALS.** — Ferrous sulfide, dilute hydrochloric acid, lead nitrate solution.

**APPARATUS.** — As in Fig. 56 for (d).

**Caution.** — Hydrogen sulfide is a poisonous gas and has an offensive odor. It should not be inhaled nor allowed to escape into the laboratory. All exercises with hydrogen sulfide should be performed in the hood.

(a) Slip a lump of ferrous sulfide carefully into a test tube, stand the tube in the rack, add 5 cc. of dilute hydrochloric acid, and *cautiously* note the odor of the gas.

(b) Wet a piece of filter paper with lead nitrate solution and hold it in the escaping gas. Note the change in color.

(c) If necessary, add a little more ferrous sulfide and dilute hydrochloric acid to the test tube, and make two tests. (1) Hold a lighted match at the mouth of the tube. Observe the flame and its color. *Cautiously* note the odor of the gaseous product. (2) Lower a cold dish down upon the flame and note the deposit on the dish.

(d) Arrange an apparatus as in Fig. 56. Fill *B* half full of water. Put ferrous sulfide and dilute hydrochloric acid in the test tube *A* and let the gas bubble through the water in the test tube *B* for a few minutes. Use the solution in **Supplementary Exercise 38**. Cork tightly, unless it is to be used soon.

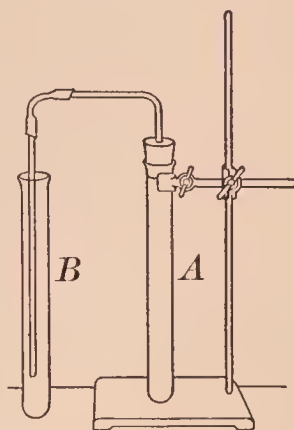

FIG. 56. — Apparatus for preparing hydrogen sulfide water

*Write answers to these questions in your laboratory notes.*

- (1) *How would you describe the odor of hydrogen sulfide?*
- (2) *What lead compound was formed in (b)? What is the chemical equation?*
- (3) *What compounds are formed by the ordinary combustion of hydrogen sulfide? What is the equation?*
- (4) *What is the effect of cooling a hydrogen sulfide flame?*
- (5) *Does hydrogen sulfide dissolve in water?*

## SUPPLEMENTARY EXERCISES ON SULFIDES

### Supplementary Exercise 37 — Preparation and Properties of Hydrogen Sulfide — Teacher's Exercise

**MATERIALS.** — Ferrous sulfide, dilute hydrochloric acid, lead nitrate solution.

**APPARATUS.** — As in Fig. 57; stoppered bottle. (The apparatus shown in Fig. 14 may be used if the lower end of the thistle tube is kept below the surface of the acid.)

**Caution.** — Hydrogen sulfide is a poisonous gas and has an offensive odor. It should not be inhaled nor allowed to escape into the laboratory. All exercises with hydrogen sulfide should be performed in the hood.

**I. Preparation.** — Construct and arrange the apparatus as shown in Fig. 57. Put 10 gm. of coarsely powdered ferrous sulfide in the bottle *A*, insert the stopper tightly, and adjust the apparatus so that the end of the delivery tube will be under the support of the pneumatic trough. Introduce a little dilute hydrochloric acid

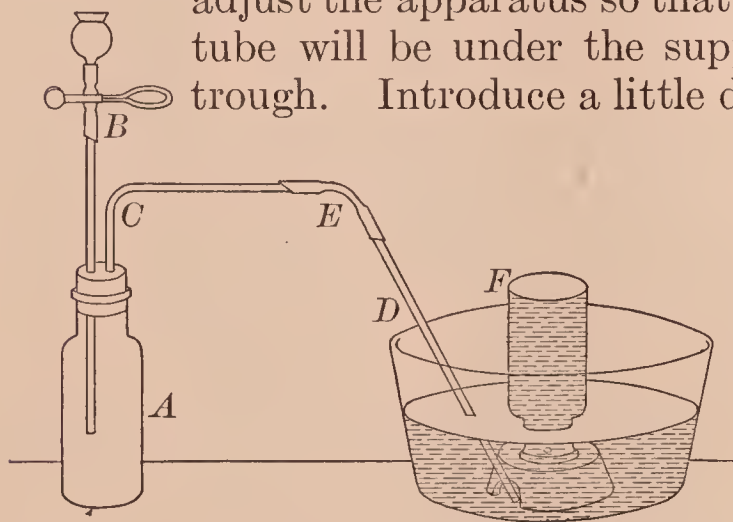

FIG. 57. — Apparatus for preparing hydrogen sulfide

through the dropping tube. Hydrogen sulfide is rapidly evolved. If the evolution of gas slackens or stops, add more hydrochloric acid. Collect three bottles, removing each as soon as full and covering tightly with a piece

of dry filter paper. Set aside until needed. When all the bottles have been filled with gas, proceed at once with II.

**II. Properties.** — (a) Waft a very little of the gas *cautiously* toward the nose, and note the odor. This odor is characteristic of hydrogen sulfide, and is a decisive test.

(b) Test the gas from the same bottle with (1) both kinds of moist litmus paper, and note if hydrogen sulfide is acid, alkaline, or neutral, and (2) a piece of filter paper wet with lead nitrate solution, and note the change in color.

(c) Hold a lighted match at the mouth of the same bottle. Observe the color of the flame. Note very *cautiously* the odor of the gaseous product.

(d) Burn another bottle of hydrogen sulfide and hold a cold, dry dish in the burning gas. Note the deposit on the dish.

(e) Pour several drops of concentrated nitric acid into a bottle of hydrogen sulfide, cover, and shake. Note the solid product.

*Write answers in your laboratory notes to the questions at the end of Exercise 47.*

*Write also answers to these questions. (6) What is the chemical equation for the reaction in I? (7) What are two tests for hydrogen sulfide? (8) How would you explain the result in II (e)?*

### Optional Exercises

1. Summarize briefly the properties of hydrogen sulfide.
2. State the experimental evidence of its composition.

### Supplementary Exercise 38 — Preparation and Properties of Sulfides — Teacher's Exercise

**MATERIALS.** — Hydrogen sulfide water, clean copper wire, bright silver coin, lead oxide (litharge); solutions of tartar emetic, zinc sulfate, cadmium nitrate, and silver nitrate; sulfur (powdered) and iron thread (or clean filings) for (d).

(a) Put 10 cc. of hydrogen sulfide water in a test tube and slip in a piece of clean copper wire and a bright silver coin. Note the result in each case after several minutes. The products are sulfides of the respective metals.

(b) Put a little litharge — the brownish yellow oxide of lead — in a test tube, cover it with hydrogen sulfide water, and warm gently. The product is lead sulfide. Note its color.

(c) Add to separate test tubes a few cubic centimeters of solutions of (1) tartar emetic (a compound of the metal antimony), (2) zinc sulfate, (3) cadmium nitrate, and



(4) silver nitrate. Add 5 cc. of hydrogen sulfide water to the solutions. Note the color of each product.

(d) Mix thoroughly on a piece of paper about 3 gm. of powdered sulfur and 5 gm. of clean iron filings. Slip the mixture into a test tube and heat intensely. Remove the test tube from the flame as soon as action begins. Remove the product by breaking the end of the test tube, add a little dilute hydrochloric acid to it, and note the result.

*Write answers to these questions in your laboratory notes.*  
(1) *What is the name, formula, and color of the sulfides formed in (a), (b), (c)?* (2) *What are the chemical equations for the reactions in (c) (2), (3), (4)?* (3) *What are the corresponding ionic equations?* (4) *What is the name and formula of the sulfide formed in (d)?* (5) *What is a test for sulfide ion?*

## CARBON — FLAME

### ★Exercise 48 — Destructive Distillation of Soft Coal and Examination of the Products

MATERIALS. — Soft coal, litmus paper, lead nitrate solution.

APPARATUS. — As in Fig. 58.

**I. Distillation.** — Fill the large test tube two-thirds full of coarsely powdered soft coal, insert the stopper with its open delivery tube, and clamp the test tube to the iron stand as shown in Fig. 58. Heat the whole tube gently at first, gradually increase the heat, and finally heat intensely the part containing the coal.

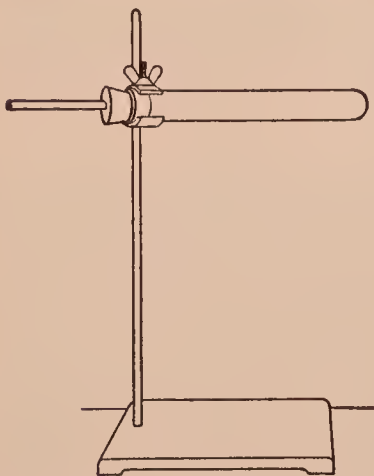

FIG. 58. — Apparatus for distilling coal

**II. Examination of the Products.** —  
(a) As soon as the gas begins to escape, lay a piece of wet red litmus paper on the end of the tube and continue to heat intensely; wet the paper, if it dries. Observe any change in the color of the litmus paper. Remove the paper.

(b) Hold at the end of the tube a piece of filter paper which has been moistened with lead nitrate solution; observe the

effect of the gas on the paper. The discoloration is caused by lead sulfide which is produced by the interaction of lead nitrate and the sulfides in the liberated gas.

(c) Heat intensely, and light the gas at the end of the tube. Observe the flame, especially the color.

(d) Discontinue heating, let the apparatus cool somewhat, disconnect, and break open the test tube. Examine the contents, and note the properties of the solid and liquid products.

*Write a brief account of this exercise in your laboratory notes.*

### ★ Exercise 49 — Distillation of Wood — Teacher's Exercise

MATERIALS. — Chips of wood, litmus paper.

APPARATUS. — As in Fig. 59.

Construct and arrange an apparatus as in Fig. 59. Fill the test tube *A* half full of chips of wood. Fill the bottle *D* half full of cold water. The test tube *C*, which serves as a condenser, is empty. The exit tube *E* is drawn out to form a small jet at the outer end. Adjust finally so that the lower end of the tube *B* is about 2.5 cm. (1 in.) from the bottom of the condenser tube *C*.

Heat the test tube *A* gently at first and then strongly where the wood is placed. Note the result in both test tubes (*A* and *C*).

Continue to heat, and bring the flame to the end of the jet tube *E*. Note the result. If no result, heat strongly and try again.

When the distillation causes no more change in the test tube *A*, stop heating, let the apparatus cool, and disconnect the two test tubes.

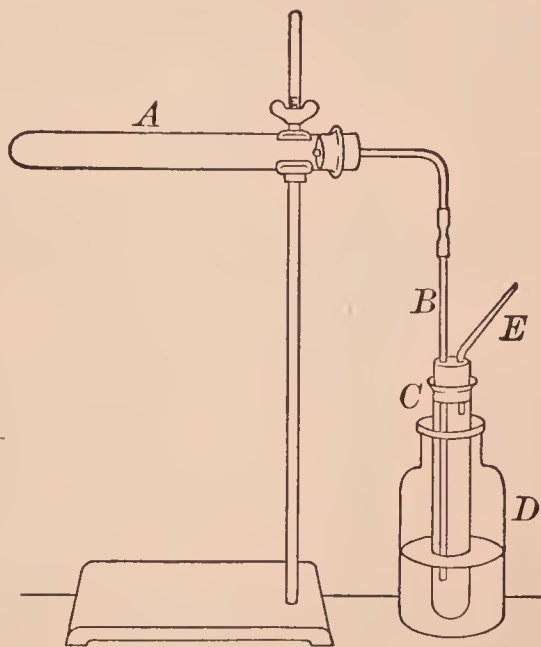

FIG. 59. — Apparatus for distilling wood

(a) Examine the contents of *A* and note its properties. Note also the conspicuous difference from the original wood.

(b) Note the contents of the test tube *C*. Smell, and note the odor. Test with blue litmus paper and note the effect.

*Write a brief description of this exercise in your laboratory notes. Write also answers to these questions. (1) What is the name of the residue in A? (2) Of the dark liquid in C? (3) What is one substance in C according to the litmus test?*

### ★Exercise 50 — Illuminating Gas Flame — Teacher's Exercise

MATERIAL. — Calcium hydroxide solution.

APPARATUS. — Gas burner (Fig. 60) or tip, glass tube.

(a) Examine a gas burner tip, noting especially the slit.

(b) If an ordinary gas burner is not available, attach the tip to a rubber tube and slip the tube over the top (or just inside) of a Bunsen burner. Light the gas. Note the yellow and black parts (Fig. 60).

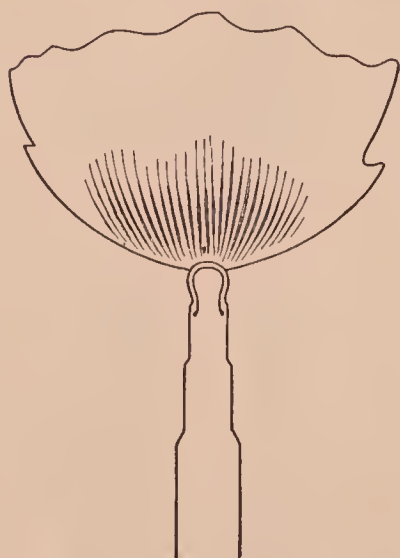

FIG. 60. — Gas burner and flame

Turn off the gas slowly until the flame is very small and note the change in the size of the parts, and finally the black and the blue parts.

Turn on the gas slowly and note the change in the size of the parts.

(c) Hold a glass tube in the upper part of the yellow flame. Note the deposit on the tube, and conclude (1) what it is and (2) where it came from. Lower the flame and hold a cold, dry bottle low down almost upon the flame. Note if a deposit is formed. If so, conclude what it is and why it was formed.

(d) Hold a cold, dry bottle mouth downward just over the flame. Note the deposit inside the bottle. Pour about 10 cc. of calcium hydroxide solution into the bottle, and shake.



Note the result. Conclude what are the two products of the combustion of illuminating gas.

*Write a brief account of this exercise in your laboratory notes, recording all observations and conclusions under the lettered and numbered parts.*

### ★Exercise 51 — Candle Flame — Teacher's Exercise

**MATERIALS.** — Candle, piece of stiff paper, calcium hydroxide solution, lead pencil, copper wire (15 cm. or 6 in. long).

Stick a short candle to a block of wood by means of a little melted candle wax.

(a) Hold a cold, dry bottle over the lighted candle. Note the product seen inside the bottle.

Remove the bottle, pour in a little calcium hydroxide solution, and shake. Note the result. Conclude what are the two main products of a burning candle.

(b) Blow out the candle flame, and immediately hold a lighted match in the escaping smoke. Note if the candle relights. Conclude (1) what is the general nature of this smoke, and (2) how it is related to the candle wax.

(c) Press a piece of stiff paper carefully for an instant down upon the steady candle flame almost to the wick. Repeat several times with different parts of the paper. Note the result. Conclude what the marks on the paper show about the structure of the flame.

(d) Roll one end of the copper wire around a lead pencil to form a spiral about 2 cm. (or 1 in.) long. Press the spiral down slowly upon the candle flame (Fig. 61). Note the result. Cool the wire and repeat. Decide upon an explanation of the result.

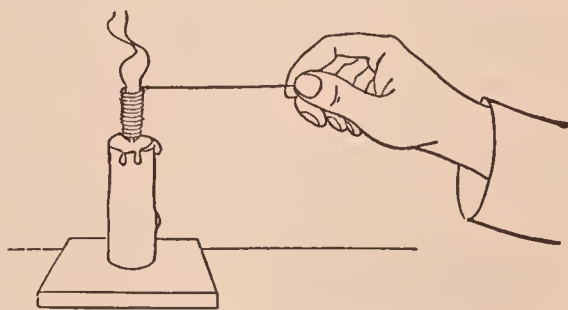

FIG. 61. — Effect of cooling a candle flame

*Write a brief account of this exercise in your notes, recording the observations and conclusions under the lettered and numbered parts.*

## Optional Exercises

1. Draw a candle flame, showing the parts.
2. Is there any essential difference between a candle and a gas or a lamp flame?
3. Why do candles and lamps often smoke?

### ★Exercise 52 — Bunsen Burner and Bunsen Burner Flame — Teacher's Exercise

**MATERIALS.** — Powdered wood charcoal, pin, copper wire, glass tube.

(a) Optional. Take apart a Bunsen burner and study the construction. Note the essential parts.

(b) Close the holes at the bottom of a lighted burner and hold a glass tube in the upper part of the yellow flame. Note the deposit. Conclude (1) what it is and (2) where it came from.

Open the holes and move the tube up and down in the colorless Bunsen flame. Note the effect on the deposit.

(c) Dip a glass tube a short distance into some powdered wood charcoal, place the end containing the charcoal in one of the holes at the bottom of the lighted burner, and blow gently two or three times into the other end. Note the result. Decide upon an explanation.

(d) Open and close the holes of a lighted burner several times. Note the result. Pinch the rubber tube to extinguish the flame, then light the gas at the holes. Note the change produced in the flame. Conclude what is the object of the holes.

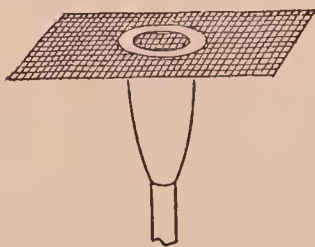

FIG. 62. — Studying the cones of a Bunsen flame

(e) (1) Lay a match across the top of the tube of a lighted Bunsen burner. When the match begins to burn, remove and extinguish it. Note where it is charred.

(2) Press a piece of wire gauze down upon the flame. Note the appearance of the gauze (Fig. 62).

(3) Stick a pin through a match near the head, and suspend it across the burner as in Fig. 63. Turn the gas on full and

light it. Note the effect, if any, on the match. Conclude what the whole of (e) shows about the structure of the lower part of the Bunsen flame. Verify your conclusion, if necessary, by (f).

(f) Hold one end of a glass tube (about 15 cm. or 6 in. long) in the Bunsen flame about 2 cm. (1 in.) from the top of the burner tube (Fig. 64).

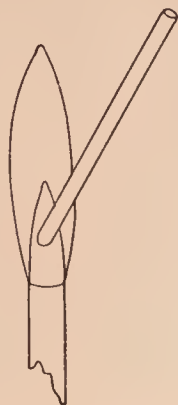

FIG. 64. — Studying the inner cone of a Bunsen flame

Hold a lighted match for an instant at the upper end of the tube; raise or lower the tube slightly (still keeping the end in the flame) and observe the result. Conclude (1) what the result shows about the structure of the Bunsen flame, and (2) how it verifies (e).

(g) Find the hottest part of the flame, when a full current of gas is burning, by moving a copper wire up and down in the flame. Measure its distance, approximately, from the top of the burner tube. Enter the result in your laboratory notes by a sketch which shows the whole flame and the location of the hottest part.

(h) Optional. Examine an imperfect Bunsen burner flame — one which shows the outlines of the inner part. Note the general shape of each main part. Draw a vertical and a cross section in your laboratory notes.

(i) Optional. Using the same burner as in (h), lower the flame gradually until it strikes back. Note (1) the odor and (2) the location of the flame.

*Write a brief account of this exercise in your laboratory notes, including under lettered and numbered parts the observations, conclusions, and sketches.*

### Optional Exercises

1. Sketch the essential parts of a Bunsen burner.
2. Examine and describe a gas range burner.
3. As in 2, a gas range burner flame. Compare it with a typical Bunsen flame.



FIG. 63. — Studying the lower part of a Bunsen flame





## \*Exercise 53 — Reduction and Oxidation with the Blowpipe

**MATERIALS.** — Charcoal, lead oxide, sodium carbonate, calcium sulfate, powdered wood charcoal, silver coin, zinc.

**APPARATUS.** — Blowpipe, blowpipe tube.

**A. Using the Blowpipe.** — Slip the blowpipe tube (Fig. 65) into the burner tube. Light the gas and lower the flame until it is about 4 cm. (1.5 in.) high. Rest the tip of the blowpipe (Fig. 66) on the top of the blowpipe tube, placing the tip just within the flame. Put the other end of the blowpipe between the lips, puff out the cheeks, inhale through the nose, and exhale into the blowpipe, using the cheeks somewhat as bellows. Do not blow in puffs, but produce a continuous flow of air through the blowpipe (Fig. 67). The flame should be an inner blue cone surrounded by an outer and almost invisible cone (Fig. 68).



FIG. 65. —  
Blowpipe  
tube

surrounded by an outer and almost invisible cone (Fig. 68).

**B. Reduction.** — (a) Make a cavity in one end of the flat side of a piece of charcoal. Fill it with a mixture of

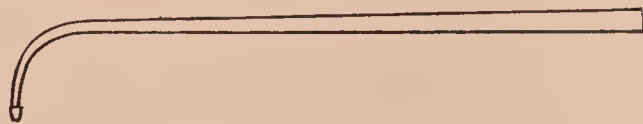

FIG. 66. — Blowpipe

equal parts of sodium carbonate and lead oxide, and heat the mixture in the reducing flame (B in Fig. 68). In a short time bright, silvery globules should appear on the charcoal. Let

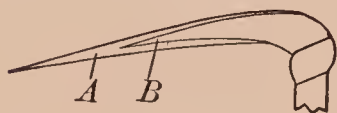

FIG. 68. — Blowpipe  
flame — A oxidizing  
and B reducing

the mass cool, and pick out the largest globules. Put one or two in a mortar, and strike with a pestle. Note if they are soft or hard, malleable or brittle. Conclude (1) whether the metal is lead and (2) if so, what became of the oxygen.

(b) Grind together in a mortar a little calcium sulfate and powdered wood charcoal, adding just enough water to hold the mass together. Heat some of this paste in the reducing



FIG. 67. — Using the  
blowpipe

flame as in (a). Scrape the mass into a test tube, boil in a little water, and put a drop of the solution on a clean silver coin. Note the result. If a dark brown stain is produced, it is evidence of the formation of silver sulfide. Repeat, if no such stain is produced. The silver sulfide is formed by the interaction of the silver and calcium sulfide. Conclude how this exercise illustrates reduction.

**C. Oxidation.** — Heat a small piece of zinc on charcoal in the oxidizing flame (A in Fig. 68). Direct the flame across the zinc so that most of the product will form a coating on the charcoal. Observe the color of the coating on the charcoal when both hot and cold.

*Write a brief account of this exercise in your laboratory notes.*

*Write also the name and formula of each obvious product of the reduction and oxidation.*

## SUPPLEMENTARY EXERCISES ON CARBON AND FLAME

### Supplementary Exercise 39 — Carbonic Acid — Teacher's Exercise

**MATERIALS.** — Marble; solutions of sodium hydroxide and phenolphthalein.

**APPARATUS.** — Carbon dioxide generator with washing tube.

Construct and arrange a carbon dioxide generator like that shown in Fig. 69. (A bottle may be used in place of the test tube A.) Put marble chips in A and water in B (to wash the acid from the gas.) Use dilute hydrochloric acid. Fill the bottle C half full of water, add a few drops of phenolphthalein solution, and just enough sodium hydroxide solution to color the liquid a faint pink (after shaking).

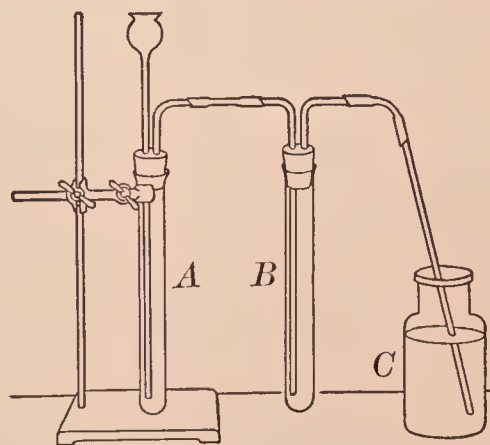

FIG. 69. — Apparatus for preparing and washing carbon dioxide

Pass a slow current of carbon dioxide through the liquid in the bottle *C* until a definite change is produced in the absorbing liquid. Note the result. Compare the final with the original liquid in *C*.

*Write a brief account of this exercise in your laboratory notes, including equations for the essential chemical change in A and in C.*

### Supplementary Exercise 40 — Acetylene — Teacher's Exercise

**MATERIALS.** — Calcium carbide, dilute potassium permanganate solution.

**APPARATUS.** — As in Fig. 70, three bottles.

**Caution.** Acetylene mixed with air explodes. Perform this exercise with great care.

**I. Preparation.** — Arrange the apparatus as in Fig. 70. Put about 5 gm. of calcium carbide in the bottle *A*. Fill the cup of the dropping tube with water, and let water drop very slowly into the bottle. Acetylene will be given off. Collect the gas over water as usual. Reject the first bottle. Collect two bottles of acetylene. Collect a third bottle of a mixture of air and acetylene thus: Fill the bottle at first only about half full of water, invert, and let the acetylene fill the bottle; set this bottle apart from the others.

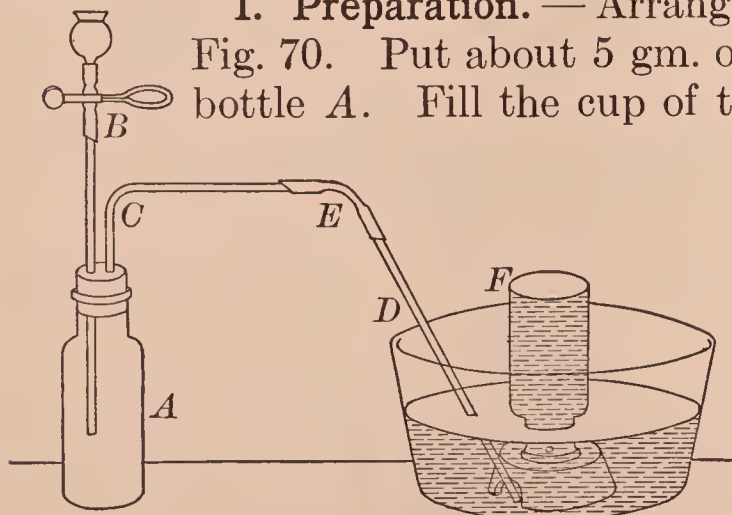

FIG. 70. — Apparatus for preparing acetylene

Reject the first bottle. Collect two bottles of acetylene. Collect a third bottle of a mixture of air and acetylene thus: Fill the bottle at first only about half full of water, invert, and let the acetylene fill the bottle; set this bottle apart from the others.

**II. Properties.** — (a) Drop a lighted match into a bottle of acetylene. Observe the flame, especially the color, luminosity, and smokiness.

(b) To another bottle of acetylene add 5 cc. of dilute potassium permanganate solution, shake well, and observe the result.



(c) Drop a lighted match cautiously into the bottle containing the mixture of acetylene and air. Note the result.

*Write a brief account of this exercise in your laboratory notes, including the equations for I, II (a), a summary of II, and an explanation of II (b).*

## ORGANIC COMPOUNDS

### Exercise 54 — Sugars (Sucrose (Cane Sugar) and Dextrose)

**MATERIALS.** — Cane sugar, glucose, sodium hydroxide and Fehling's solution; (optional) substances enumerated in (c).

(a) Add 10 cc. of Fehling's solution (see APPENDIX, § 13, LIST G) to 5 cc. of dextrose solution, and heat to the boiling point. Note the precipitate. It is cuprous oxide. Note especially the color.

(b) Repeat (a), using sucrose (cane sugar) solution instead of glucose. Heat, but do not boil the mixed solutions. Note the result. Compare with (a).

(c) Optional. Apply Fehling's test for dextrose (and similar sugars) to cheap candy, maple sugar, molasses, table sirups, jelly, jam, fruits. Prepare and use clear solutions. Note each result.

(d) Put 10 cc. of sucrose solution in an evaporating dish, add 1 cc. of concentrated hydrochloric acid, and boil about ten minutes. Neutralize with sodium hydroxide solution (mix well), and test with Fehling's solution. Note the result.

*Write answers to these questions in your laboratory notes.*

(1) *What is a test for glucose?* (2) *How can sucrose be distinguished from glucose?* (3) *Optional. What does (c) show about the distribution of glucose?* (4) *How does (d) illustrate hydrolysis and inversion?* (5) *What is the formula of cuprous oxide?*

## Exercise 55 — Properties of Starch

**MATERIALS.** — Starch, Fehling's solution, dilute iodine solution.

Prepare a starch mixture by boiling about 1 gm. of powdered starch for a few minutes in 50 cc. of water; stir or agitate the mixture during the boiling. Make these tests with the starch mixture.

(a) (1) Pour half of it into an evaporating dish which stands on a gauze-covered ring, add 2 cc. of concentrated hydrochloric acid, mix well, and boil gently for ten minutes; add water occasionally to replace that lost by evaporation. Meanwhile proceed with (b).

(2) As soon as the mixture in (1) has been boiled ten minutes, take out a little, add sodium hydroxide solution to alkaline reaction (shake well), and apply Fehling's test. Note the result. Continue the heating for ten or more minutes, and test again. Note the final result. Compare with (b).

(b) To 10 cc. of the original starch mixture add 10 cc. of Fehling's solution, shake, and warm. Observe the result. Save for comparison with (a).

(c) Add a drop or two of very dilute iodine solution to the rest of the starch mixture. Observe the color. (This test for starch is delicate, and dilute mixtures should be used.)

(d) Test potato, rice, and bread for starch by moistening each separately with water, and then adding a drop or two of very dilute iodine solution. Note the result in each case.

*Write answers to these questions in your laboratory notes.*

(1) *What is the result of boiling starch with acid?* (2) *Does starch react with Fehling's solution?* (3) *What effect does iodine have on starch?*

## Exercise 56 — Testing Baking Powders

**MATERIALS.** — Baking powder (tartrate, phosphate, alum), vinegar, sour milk, lemon juice, solutions of calcium hydroxide, iodine, silver nitrate, ammonium chloride, sodium hydroxide, ammonium molybdate and ammonium oxalate.

**NOTE.** — Different varieties of baking powder may be tested by individuals or sections, and the results compared.

(a) **Carbonates.** — (1) Put a little baking powder in a test tube, add a few drops of dilute hydrochloric acid, and test the escaping gas for carbon dioxide with a tube which has been dipped into calcium hydroxide solution (Fig. 71). Note the result.

(2) Put 2 gm. of baking powder in a test tube, add 15 to 20 cc. of water, and shake well. Let the action continue a short time, and then test the solution as in (1). Note the result.

(3) Add sour substances, *e.g.* vinegar, sour milk, lemon juice, separately to a little baking powder, and note the result.

(b) **Starch.** — Apply the iodine test for starch to a little baking powder mixed with water. Note the result.

(c) **Tartrates.** — Prepare a cold solution of baking powder by shaking about 10 gm. of the substance with 50 cc. of water and stirring until all the gas is liberated. (It is better to boil it, and then cool it for use.) Filter, if not clear, and use the clear solution in this and succeeding tests.

(1) Clean a test tube by boiling sodium hydroxide solution in it and then washing thoroughly with water. Put 10 cc. of silver nitrate solution in the cleaned test tube, and add ammonium hydroxide slowly until the precipitate at first formed redissolves, taking care to mix the solutions. Add 10 cc. of the baking powder solution and warm gently. Tartrates, if present, will reduce the silver compound to silver, which will coat the inside of the test tube.

(2) Put about 5 cc. of the prepared solution in an evaporating dish, add a few drops of concentrated sulfuric acid, and heat gently. Tartrates, if present, will char and smell like burnt sugar.

(d) **Sulfates.** — To 5 cc. of the baking powder solution (prepared as above) add dilute hydrochloric acid to acid reaction and boil (to remove any carbon dioxide); then test with barium chloride solution. Note the result.

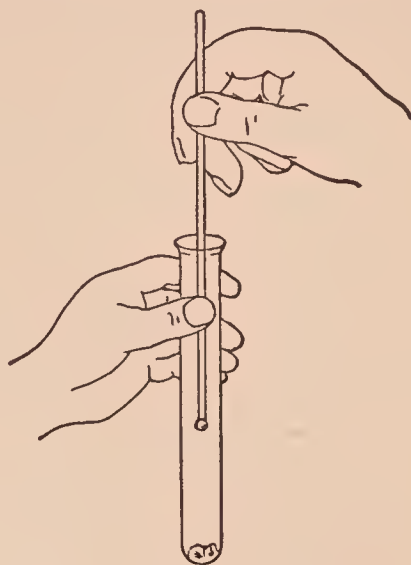

FIG. 71. — Testing for carbon dioxide



(e) **Phosphates.** — Warm 5 cc. of the baking powder solution, acidify with concentrated nitric acid, and add 5 cc. of ammonium molybdate solution. A yellow precipitate indicates phosphates. Note the result.

(f) **Ammonium salts.** — Boil 5 cc. of the baking powder solution with an equal volume of sodium hydroxide solution. The presence of ammonium salts is shown by the liberation of ammonia gas, which can be detected by its odor. Note the result.

(g) **Aluminum salts.** — Boil 5 cc. of the baking powder solution with 1 or 2 cc. of dilute hydrochloric acid, filter if not clear, and add 10 cc. (or more) of ammonium chloride and 10 cc. of ammonium hydroxide to the filtrate. A whitish flocculent precipitate (aluminum hydroxide) indicates aluminum salts. Note the result.

(h) **Calcium salts.** — Boil 10 cc. of the baking powder solution with dilute hydrochloric acid (to remove any carbon dioxide), add ammonium hydroxide to alkaline reaction (stir, and test with litmus paper), filter, if not clear, and then add ammonium oxalate solution. Calcium compounds produce a white precipitate (calcium oxalate). Note the result.

*Write the results of these tests in tabular form in your laboratory notes.*

## SUPPLEMENTARY EXERCISES ON ORGANIC COMPOUNDS

### Supplementary Exercise 41 — Esters

**MATERIALS.** — Acetic acid, ethyl alcohol, calcium butyrate, methanol, salicylic acid.

(a) Cautiously add 3 or 4 drops of concentrated sulfuric acid to a mixture of 5 cc. each of acetic acid and ethyl alcohol. Shake the mixture and warm gently. Note the odor. It is due to the ester called ethyl acetate.

(b) Put a very little calcium butyrate in a test tube, add 2 or 3 cc. of water, the same volume of ethyl alcohol, and 3

or 4 drops of concentrated sulfuric acid. Shake well, and warm gently. The ester produced is ethyl butyrate. Note the odor.

(c) Proceed as in (b), using salicylic acid, methanol, water, and concentrated sulfuric acid. The ester is methyl salicylate. Note the odor.

*Write a brief account of this exercise in your laboratory notes. In your notes write this equation in complete form:*

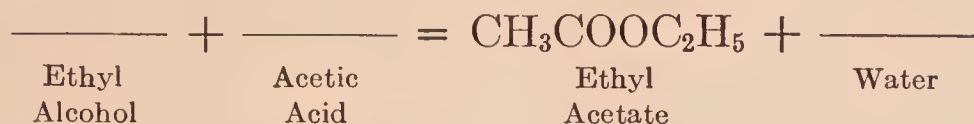

### Supplementary Exercise 42 — Soap

**MATERIALS.** — Sodium hydroxide, lard, soap, phenolphthalein, and (saturated) salt solution.

**I. Preparation.** — (a) Dissolve 10 gm. of sodium hydroxide in 75 cc. of water, add 30 gm. of lard, and boil the mixture in a porcelain (or metal) dish for an hour or more; add water occasionally to replace that lost by evaporation. Then add about 50 cc. of a saturated salt solution. Stir constantly during the addition of the solution. Let the mass cool, and remove the cake of soap.

(b) Optional. Prepare soap by the method given on a can of commercial "lye."

**II. Properties.** — (a) Leave soap shavings exposed to the air for several days. Note the result.

(b) (1) Test the soap made in I with wet litmus paper. Note the result. Test other samples and compare.

(2) Put a few drops of phenolphthalein solution (alcoholic) on samples of dry soap. Note the results. This is a test for "free alkali."

(c) Prepare 25 cc. of a solution of the soap made in I (a). Warm it and examine the surface for fat (film or globules). Note the result.

(d) Add 20 cc. of dilute sulfuric acid to 10 cc. of soap solution. Note the result. The precipitate is a mixture of palmitic and stearic acids.

Write a brief account of I in your laboratory notes.

Write also answers to these questions. (1) What does II (a) show about water in soap? (2) What does II (b) show about alkali in soap? (3) Was fat detected in II (c)? Why?

### Optional Exercises

1. Complete this equation :

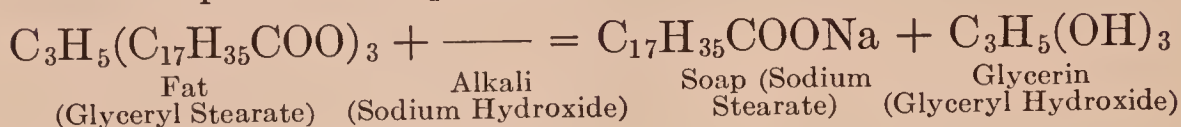

2. Complete this equation :

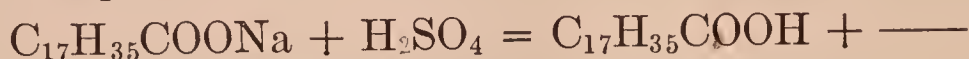

### Supplementary Exercise 43 — Testing for Nutrients in Food — Teacher's Exercise

**MATERIALS.** — Foods; Molisch's, iodine, Fehling's, and sodium hydroxide solutions; gasolene, concentrated nitric acid, very dilute copper sulfate solution.

Apply tests for carbohydrate, fat, and protein to various foods.

**I. Carbohydrate.** — (a) Apply the Molisch test. To 5 cc. of a clear dilute solution of the carbohydrate (or food), add 2 cc. of Molisch's solution, and shake. Incline the test tube and carefully pour down the inside 5 cc. of concentrated sulfuric acid so that two layers will form. At the contact zone a red-violet color will appear slowly. Note the result.

(b) Apply the iodine test for starch (**Exercise 55**) and Fehling's test for sugar (**Exercise 54**). Note each result.

**II. Fat.** — Grind the sample with gasolene (Care!) in a mortar, pour off the gasolene into an evaporating dish, let it evaporate, and examine the residue. Rub a little between the fingers. Burn a little on the end of a glass rod. Note each result.

**III. Protein.** — (NOTE. — Use two or more of these tests.)

(a) Grind the sample with 20 cc. of water in a mortar, pour off the water (filter, if not clear). To about 5 cc. of the dilute extract add an equal volume of sodium hydroxide solution



and shake well. Then add drop by drop a very dilute copper sulfate solution. A violet color is produced. Note each result.

(b) To 5 cc. of the extract from (a) add an equal volume of concentrated nitric acid. Heat gently until a yellow precipitate, or a yellow solution, is obtained. Cool in running water and add an excess of sodium hydroxide solution. An orange color is produced. Note each result.

(c) To 5 cc. of the extract from (a) add concentrated nitric acid slowly, pouring the acid down the inside of the tube so the two solutions will not mix. A white cloudy precipitate is formed at the surface where the two liquids meet. Note each result.

*Write the results of these tests in tabular form in your laboratory notes.*

## SUPPLEMENTARY EXERCISES ON BROMINE AND IODINE

### Supplementary Exercise 44 — Preparation and Properties of Bromine — Teacher's Exercise

**MATERIALS.** — Potassium bromide, manganese dioxide, dilute sulfuric acid.

**APPARATUS.** — As in Fig. 72; bottle half full of water and fitted with a cork. The large test tube has a one-hole rubber stopper to which is fitted the bent glass tube; the total length of the glass tube is about 30 cm. (12 in.).

**Caution.** — Bromine is a corrosive liquid, which readily forms a suffocating vapor. Perform all exercises with bromine carefully in the hood.

Put about 3 gm. of potassium bromide in a large test tube, and add 10 cc. of dilute sulfuric acid. Insert the stopper and its tube (Fig. 72), attach the test tube holder, and warm gently. Bromine vapor soon appears in the test tube and, if the heat is sufficient, some vapor will escape from the delivery tube.

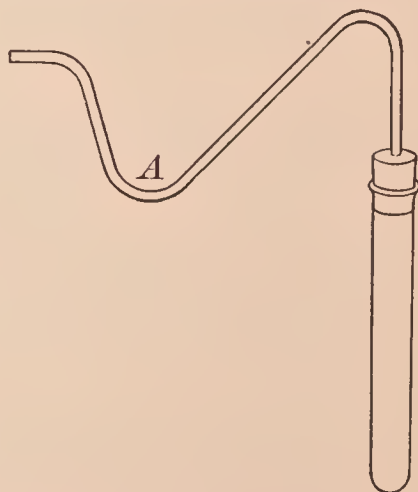

FIG. 72. — Apparatus for preparing bromine

Note the color and *very cautiously* the odor of the bromine vapor. Note also if it is heavier or lighter than air. Hold a moist piece of bright colored cloth or paper in the vapor, and note the effect on the color.

Continue to heat, and regulate the temperature so that the vapor will condense and collect in the bend *A* of the delivery tube. When no further heating produces bromine vapor in the test tube, transfer the bromine from the delivery tube into a bottle half full of water by holding the end of the delivery tube over the mouth of the bottle and heating the test tube slightly; the expanding gases will force the liquid bromine out of the bend into the bottle.

Observe the physical properties of the liquid bromine, especially the color, solubility in water, heaviness (compared with water), and volatility. As soon as these observations have been made, cork the bottle tightly and shake it vigorously. Observe the solubility of bromine in water.

NOTE. — In the hood wash the delivery tube free from bromine, taking care to get none on the hands. Wash the test tube and throw the contents of the test tube into a waste jar in the hood.

*Write in your laboratory notes (1) the equation for preparing bromine and (2) a summary of the properties of bromine.*

### **Supplementary Exercise 45 — Preparation and Properties of Bromine (Short Method)**

MATERIALS. — Potassium bromide, manganese dioxide, dilute sulfuric acid, bright colored paper.

**Caution.** — See **Supplementary Exercise 44.**

Put a little powdered potassium bromide and twice its bulk of manganese dioxide in a test tube, and mix by shaking. Add 5 cc. of dilute sulfuric acid, or just enough to moisten the mixture well. Attach a test tube holder and heat gently. Bromine vapor is evolved.

Note the color and *very cautiously* the odor.

If the vapor condenses on the inside of the test tube, note the color and heaviness of the liquid bromine.

Stand the test tube in the test tube rack, hold a moist piece of bright colored paper in the bromine vapor, and note the effect on the paper.

*Write in your laboratory notes (1) the equation for the preparation of bromine and (2) a summary of the properties of bromine.*

### Supplementary Exercise 46 — Tests for Free Bromine and for Bromine Combined in a Bromide

MATERIALS. — Potassium bromide (solid and solution), silver nitrate solution, carbon tetrachloride, chlorine water (see APPENDIX, § 13, LIST G.), bromine water (for (a)).

(a) To 5 cc. of dilute bromine water add 5 cc. of carbon tetrachloride, shake well, and note the color of the carbon tetrachloride (lower layer), which is caused by free bromine.

(b) Add a little concentrated sulfuric acid to a little potassium bromide in a test tube; warm slightly, if the action is not marked. Observe the result, noting especially the color of the liquid or of the vapor just above the liquid.

(c) Add 5 cc. of potassium bromide solution to a test tube half full of water, then add a little silver nitrate solution, and shake. Observe the properties of the precipitate, especially the color and texture.

Test the precipitate by warming a little of it in ammonium hydroxide. Note the ease or difficulty of dissolving. Compare silver bromide and silver chloride (**Exercise 26 (c)**) in this respect.

(d) To 5 cc. of a solution of potassium bromide add a little chlorine water and a few drops of carbon tetrachloride, and shake. Note the color of the carbon tetrachloride (lower layer), which is caused by the liberated bromine.

*Write in your laboratory notes concise statements of the tests for (1) free bromine and (2) combined bromine.*



## Supplementary Exercise 47 — Preparation and Properties of Iodine — Teacher's Exercise

**MATERIALS.** — Potassium iodide, manganese dioxide, concentrated sulfuric acid, cotton, alcohol, carbon tetrachloride, potassium iodide solution.

**APPARATUS.** — As in Fig. 73.

Grind together in a mortar about 3 gm. of potassium iodide and 5 gm. of manganese dioxide. Put the mixture in a test tube, add about 3 cc. of water, 5 cc. of concentrated sulfuric acid, and mix well. Clamp the test tube vertically to an iron stand (Fig. 73). Close the inner end (*A* in Fig. 73) of the stem of the funnel with a small plug of cotton. Hold, or place, the funnel over the mouth of the test tube, and heat the test tube gently. The vapor of the liberated iodine will fill the test tube, and crystals will form in the upper part of the test tube and in the funnel. Continue to heat until enough iodine for several exercises collects in the funnel. Scrape the crystals into a dish.

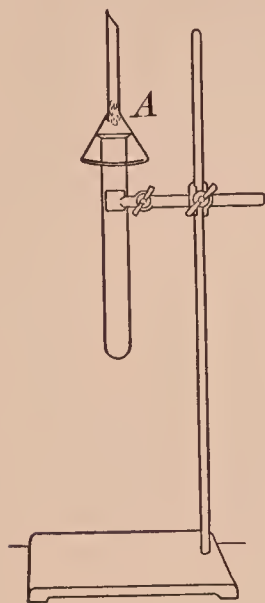

FIG. 73. — Apparatus for preparing iodine

(*a*) Observe the color of the solid and of the vapor, and the odor (*cautiously*).

(*b*) Determine the volatility by putting a small piece in a test tube and heating gently.

(*c*) Heat a small piece quickly in a dry test tube, invert the test tube when it is full of vapor, and note what the result shows about the heaviness of iodine vapor.

(*d*) Touch a crystal with the finger, and note the color of the stain.

(*e*) Determine the solubility by shaking a small piece separately in 5 cc. of water, alcohol, carbon tetrachloride, and potassium iodide solution. Note these results.

**NOTE.** — If crystals are left, use them in the next exercise. If not used at once, preserve the iodine in a stoppered bottle.

Write in your laboratory notes (1) the equation for preparing iodine and (2) a summary of the properties of iodine.

## Supplementary Exercise 48 — Preparation and Properties of Iodine (Short Method)

MATERIALS. — Potassium iodide, manganese dioxide, concentrated sulfuric acid.

Proceed as in **Supplementary Exercise 45** using potassium iodide in place of potassium bromide. Note the color and *cautiously* the odor of the vapor. Note the easy condensation of iodine vapor and the color of the condensed iodine. Omit the bleaching test.

*Write in your laboratory notes (1) the equation for the preparation of iodine and (2) a summary of the properties of iodine.*

## Supplementary Exercise 49 — Tests for Free Iodine

MATERIALS. — Very dilute iodine solution, carbon tetrachloride, cold starch mixture.

(a) Add a few drops of carbon tetrachloride to 5 cc. of very dilute iodine solution. Shake well, and observe the color of the carbon tetrachloride (lower layer) which is caused by free iodine.

(b) Add 5 cc. of a cold starch mixture to a test tube nearly full of water, and then add a few drops of very dilute iodine solution. Note the color. Pour about 5 cc. of the liquid into a test tube nearly full of water and shake. Note the color. (The blue color is due to the action of free iodine on starch. This is a delicate test for both iodine and starch.)

*Write in your laboratory notes the two tests for free iodine.*

## Supplementary Exercise 50 — Tests for Iodine Combined in an Iodide

MATERIALS. — Potassium iodide (solid and solution), chlorine water, cold starch mixture, carbon tetrachloride, silver nitrate solution.

(a) Add a little concentrated sulfuric acid to a little potassium iodide in a test tube. Observe the result, especially the color of the vapor.

(b) Add a few drops of carbon tetrachloride to a very dilute solution of potassium iodide. Then add several drops of chlorine water, and shake well. Note the color of the carbon tetrachloride (lower layer).

(c) Add 5 cc. of cold starch mixture to 10 cc. of a dilute solution of potassium iodide. Add a few drops of chlorine water, and shake well. Observe the result, especially the color.

(d) To 5 cc. of potassium iodide solution, add a little silver nitrate solution, and shake. Observe the properties of the precipitate, especially the color and texture. Test the solubility of a little of the precipitate in ammonium hydroxide, and note the result. Compare the solubility of silver iodide in ammonium hydroxide with silver chloride and silver bromide (see **Exercise 26 (c)** and **Supplementary Exercise 46 (c)**).

*Write in your laboratory notes concise statements of the tests for iodine combined in an iodide.*

## SUPPLEMENTARY EXERCISES ON SODIUM

### Supplementary Exercise 51 — Preparation and Properties of Sodium Bicarbonate — Teacher's Exercise

**MATERIALS.** — Ammonium carbonate, ammonium hydroxide, sodium chloride.

**APPARATUS.** — Carbon dioxide generator (see Fig. 74).

**I. Preparation.** — Put 8 gm. of powdered ammonium carbonate and 75 cc. of ammonium hydroxide into a bottle; add about 35 gm. of fine sodium chloride, cork the bottle, and shake the mixture vigorously until most of the solid has dissolved. Pour off the clear solution into the bottle *C* (Fig. 74).

Construct a carbon dioxide generator (see **Supplementary Exercise 39**) like that shown in Fig. 74. Put about 20 gm. of marble in the generator bottle *A*, 25 cc. of water in the tube *B*, introduce dilute hydrochloric acid as usual, and pass carbon dioxide slowly through the solution in the bottle *C*



from thirty to forty-five minutes (or less, if a precipitate forms). Then remove the generator, cork the bottle *C*, and let it stand an hour or more to allow the sodium bicarbonate to settle out of the solution. Filter, and wash quickly with a very little cold water. Dry the precipitate between filter paper. (NOTE. — If only a little of the precipitate is formed, use sodium bicarbonate from the laboratory bottle for II.)

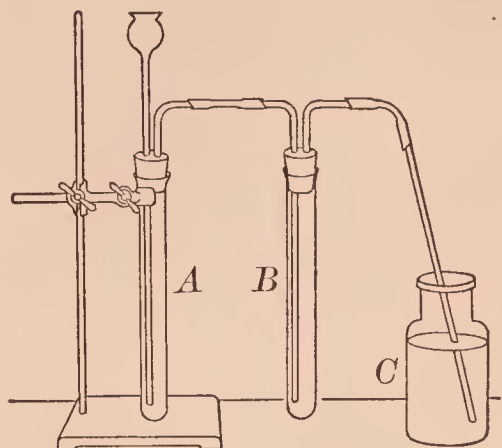

FIG. 74. — Apparatus for preparing carbon dioxide free from acid

**II. Properties.** — (a) Apply to small portions of the precipitate (1) the flame test for sodium and (2) the usual test for a carbonate. State the results.

(b) Put a little on moist litmus paper (both colors). Note the result.

(c) Heat a little in a test tube inclined so that the open end is the lower. Note the visible product. Apply the usual test for carbon dioxide to the gas in the test tube; note the result. Continue to heat until there is no further evidence of change. Determine what the final residue is by applying to it tests for sodium, a bicarbonate as in (a) and (b), and sodium carbonate (*e.g.* litmus test). Note the results.

*Write a brief account of I in your laboratory notes.*

*Write also a summary of the properties of sodium bicarbonate based on II.*

### Supplementary Exercise 52 — Preparation of Sodium Chloride in Four Ways — Teacher's Exercise

**MATERIALS.** — Sodium, sodium carbonate, sodium sulfate solution, barium chloride solution.

**APPARATUS.** — Chlorine generator, deflagrating spoon.

**A. Direct combination.** Prepare a bottle of chlorine in the hood. Remove a lump of sodium from the bottle, cut off a small piece, put the lump back, cover the small piece

with a mortar. Put a little sand or a bit of asbestos in the bowl of a deflagrating spoon, lay the sodium on it, heat gently until it melts and begins to burn, then lower the spoon carefully into the bottle of chlorine. Vigorous chemical action takes place. As soon as it is over, remove the spoon and put it in a safe place. Note the white product in the bottle. Scrape out some, taste it, and decide what it is.

**B. Neutralization.** As in **Exercise 29**.

**C. By Forming a Volatile Product.** Put a small lump of sodium carbonate in an evaporating dish, carefully add dilute hydrochloric acid, and stir until effervescence (bubbling of gas) ceases. Evaporate to dryness, redissolve the product in a little water, evaporate again, and find out what the product is by (1) tasting cautiously and (2) testing — flame test and precipitation test (for a chloride). Note the results.

**D. By Forming an Insoluble Product.** To 15 cc. of sodium sulfate solution add barium chloride solution slowly, and stop between additions to let the precipitate settle. Continue to add the barium chloride solution until precipitation ceases. Let the precipitate settle. Pour off the clear liquid, and test it for sodium chloride, *i.e.*, by flame test and precipitation test. Note the results.

*Write in your laboratory notes a summary of the four ways of preparing sodium chloride.*

*Write also the equation for each reaction.*

## CALCIUM COMPOUNDS

### **\*Exercise 57 — Properties of Calcium Carbonate, Calcium Oxide, and Calcium Hydroxide**

**MATERIALS.** — Calcium carbonate, calcium oxide; sodium carbonate and calcium hydroxide solutions.

**A. Calcium Carbonate.** (*a*) Put a drop or two of dilute hydrochloric acid on one or more specimens of calcium carbonate. Note the result in each case. Conclude what gas

is evolved. (This reaction is the usual test for a carbonate.)

(b) Attach a small lump of marble to a test wire, or lay it on a wire gauze, and heat it intensely for ten or fifteen minutes. Test it for a carbonate and note the result.

(c) Add 5 cc. of sodium carbonate solution to 5 cc. of calcium chloride solution. Note the precipitate. Decide what it is. (This reaction is often used as a test for soluble carbonates.)

### **B. Calcium Oxide and Hydroxide. I. Preparation. —**

(a) Prepare calcium oxide as in A (b). Let the residue cool, put it in an evaporating dish, and add a little water. Observe the result. Test the liquid with red litmus paper. Apply the flame test for calcium. Note the results.

(b) Prepare solid calcium hydroxide by adding a small amount of water slowly to a lump of lime. Save for III.

**II. Properties of Calcium Oxide. —** (a) Put a large lump of fresh calcium oxide on a glass plate or block of wood and let it remain exposed to the air for a few days. Examine it at intervals and note the change. Conclude as to the effect of air on calcium oxide.

(b) Pour water upon a lump of fresh calcium oxide and note any change in temperature. Decide upon an explanation of the change, if any.

**III. Properties of Calcium Hydroxide. —** (a) Add a little solid calcium hydroxide to a test tube half full of water and shake vigorously. Let the suspended solid settle somewhat, and filter. Pour half the filtrate into an evaporating dish and evaporate it to dryness; save the other half. (Meanwhile perform (b).) When evaporated, compare the amount of residue in the dish with the amount of solid originally shaken with water. Draw a conclusion regarding the solubility of calcium hydroxide in water.

(b) Taste *cautiously* of the solution saved from (a), and describe the taste. Determine the reaction toward litmus. Heat the solution slowly to boiling, and note the result. Conclude as to the effect of increased heat on the solubility of calcium hydroxide in water.



- (c) (1) Expose calcium hydroxide solution to the air, and (2) exhale the breath through calcium hydroxide solution (Fig. 75). Note each result. Conclude what is the product.

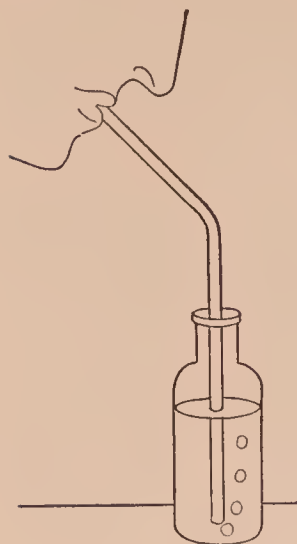

FIG. 75. — Breathing into calcium hydroxide solution

Write a brief explanation of the results in **A** (a), (b), (c) in your laboratory notes, including the verbal and chemical equations.

Write answers to these questions in your laboratory notes. (1) What calcium compound is formed by heating calcium carbonate? What is the equation? (2) What substance in air produces the marked change in calcium oxide? (3) In calcium hydroxide solution? (4) What are the equations for **I** (b), **II** (a), **III** (c)? (5) What is the reaction of calcium hydroxide toward litmus?

- (6) What is the effect of increased heat on the solubility of calcium hydroxide?

### \*Exercise 58 — Calcium Compounds and Hardness of Water — Teacher's Exercise

**MATERIALS.** — Calcium hydroxide, solutions of soap, calcium sulfate, sodium carbonate, and borax.

**APPARATUS.** — Carbon dioxide generator (see Fig. 69, **Supplementary Exercise 39**).

**A. Temporary Hardness.** — Prepare a solution of acid calcium carbonate by passing carbon dioxide free from hydrochloric acid into a mixture of 25 cc. of saturated calcium hydroxide and 25 cc. of water until the precipitate formed is redissolved.

(a) To 15 cc. of the clear acid calcium carbonate solution add 5 cc. of soap solution. Shake well and observe the product. Rub some between the fingers and note the result.

(b) Boil vigorously 15 cc. of acid calcium carbonate solution for a few minutes, filter, and add 5 cc. of soap solution. Shake well and observe the result. Compare the results of (a) and (b).

(c) To 10 cc. of clear acid calcium carbonate solution add 5 cc. of saturated calcium hydroxide, shake, filter, and to the clear filtrate add 5 cc. of soap solution. Shake well and observe the result. Compare the results of (a), (b), and (c).

**B. Permanent Hardness.** — (a) Proceed as in **A** (a), using 15 cc. of calcium sulfate solution (instead of acid calcium carbonate solution). Compare the results of **B** (a) and **A** (a).

(b) Boil 15 cc. of calcium sulfate solution, add 5 cc. of soap solution, and shake. Compare the results of **B** (a), (b), and **A** (b).

(c) To 15 cc. of calcium sulfate solution add 10 cc. of sodium carbonate solution, filter, add 5 cc. of soap solution, and shake well. Compare the results of **B** (b) and **B** (c).

**C.** Try the effect of (a) ammonium hydroxide (in excess, as told by the odor), and (b) borax solution on both temporarily and permanently hard water. Note the result.

*Write a brief account of this exercise in your laboratory notes, (1) designating the parts by letters and (2) making a brief general statement about each kind of hard water.*

## SUPPLEMENTARY EXERCISES ON CALCIUM COMPOUNDS

### Supplementary Exercise 53 — Tests for Calcium in Compounds

**MATERIALS.** — Calcium compounds (powdered), ammonium oxalate and sodium carbonate solutions.

(a) Apply the flame test to several calcium compounds, using a clean test wire in each case. Observe the color of the flame and decide upon an accurate name for it. (NOTE. — The chloride gives a typical result.)

(b) Add an excess of ammonium oxalate solution to calcium chloride solution, and note the result. The precipitate is calcium oxalate. Divide it into two parts. To (1) add an excess of dilute hydrochloric acid, warm gently, and note the final result. To (2) add considerable acetic acid and warm gently; note the final result and compare with (1).

(c) Add an excess of sodium carbonate solution to calcium chloride solution, and note the result. Decide what the precipitate is. Divide it into two parts, and treat with the acids as in (b). Note the results and compare with (b).

(d) Suggest a way to test for calcium in calcium carbonate and calcium sulfate. Try it, and record the result in your laboratory notes.

(e) Optional. Apply tests for calcium to one or more of these: Mortar, plaster, tooth powder, cement, whiting. Record each result.

*Write a brief statement of the distinctive tests for calcium in your laboratory notes.*

### Supplementary Exercise 54 — Properties of Cement — Teacher's Exercise

MATERIALS. — Cement, sand, 2 elastic bands.

(a) Mix a little cement with enough water to form a thick paste, and spread a thin layer on a block of wood or a glass plate. Let it remain undisturbed for a day or more. Then examine, and note the condition of the cement.

(b) Prepare two paper cylinders (about 8 cm. (or 3 in.) long) by rolling a piece of paper around a test tube. Close one end of each by folding over the edges of the paper.

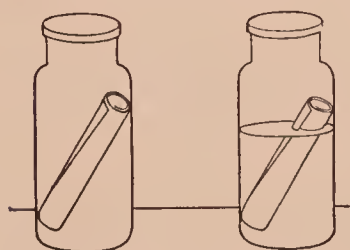

FIG. 76. — Testing  
cement

Fill an evaporating dish not quite half full of cement, add about the same bulk of sand, and mix well. Add water and stir until a soft paste is formed. Pour the mixture into each paper cylinder until full and slip an elastic band over the upper end to hold the paper in place. Lower one cylinder into a bottle of water and the other into an empty bottle (Fig. 76). Let both stand for a day or two. Then remove, unroll the paper, and compare the contents.

*Write a brief account of this exercise in your laboratory notes.*



## Supplementary Exercise 55 — Plaster of Paris — Teacher's Exercise

MATERIALS. — Plaster of Paris, vaseline.

Mix a little plaster of Paris with enough water to form a thick paste. Put the paste on a block of wood or a glass plate. Rub a very little vaseline on one side of a coin, and press the coin, coated side down, into the paste. Let it remain undisturbed for fifteen or more minutes. Then remove the coin carefully, and examine the hardened plaster.

*Write a brief account of this exercise in your laboratory notes.*

## IRON

### Exercise 59 — Tests for Iron Salts

MATERIALS. — Solutions of ferrous sulfate (prepared as needed from crystals which have been thoroughly washed in cold water), ammonium hydroxide, potassium ferricyanide, ferric chloride, potassium ferrocyanide, and potassium thiocyanate.

**A. Ferrous Salts.** — (1) Add 5 cc. of ammonium hydroxide to 5 cc. of ferrous sulfate solution. Shake well. The precipitate is ferrous hydroxide. Note the color *at once*. Shake, and note the changes in color.

(2) Add 5 cc. of potassium *ferricyanide* solution to 5 cc. of ferrous sulfate solution. Shake well. The precipitate is ferrous ferricyanide. Note the color. (This is the best test for a ferrous salt.)

**B. Ferric Salts.** — (1) Add 5 cc. of ammonium hydroxide to 5 cc. of ferric chloride solution. The precipitate is ferric hydroxide. Note the color and texture.

(2) Add 5 cc. of potassium ferrocyanide solution to 5 cc. of ferric chloride solution. The precipitate is ferric ferrocyanide. Note the color and texture.

(3) Add 5 cc. of potassium thiocyanate solution to 5 cc. of ferric chloride solution. Note the result. The red colored solution is due to soluble ferric thiocyanate. (This is the best test for a ferric salt.)

C. Try (a) potassium ferricyanide and ferric chloride and (b) potassium thiocyanate and ferrous sulfate.

Write the results of this exercise in your laboratory notes in tabular form, thus: —

IRON SALT	AMMONIUM HYDROXIDE	POTASSIUM FERRICYANIDE	POTASSIUM FERROCYANIDE	POTASSIUM THIOCYANATE
A. Ferrous				
B. Ferric				

Write also in your laboratory notes the best test for (1) ferrous and (2) ferric salts.

### Exercise 60 — Reduction and Oxidation of Iron Salts

MATERIALS. Ferric chloride solution, ferrous sulfate solution (freshly prepared from crystals washed with cold water), potassium chlorate, zinc.

**A. Reduction.** — Put a piece of zinc in 10 cc. of ferric chloride solution, and add a few drops of concentrated hydrochloric acid. Warm gently about ten minutes, and test separate portions of the solution for a ferrous and a ferric salt (use the best single test). Note the results.

**B. Oxidation.** — (a) To 10 cc. of the freshly prepared ferrous sulfate solution add a few drops of concentrated hydrochloric acid, three or four crystals of potassium chlorate, and warm gently about five minutes. Test separate portions of the solution for a ferrous and a ferric salt. Note the results.

(b) Add a few drops of concentrated sulfuric acid to 10 cc. of ferrous sulfate solution, shake and then add 10 cc. of concentrated nitric acid drop by drop. Boil carefully. Test as in (a) and note the results.

Write a brief account of this exercise in your laboratory notes.

## METALS — DISPLACEMENT AND TESTS

### ★Exercise 61 — Displacement of Metals

MATERIALS. — Copper wire and strips of zinc, solutions of copper sulfate, mercuric chloride (Poison), silver nitrate, lead nitrate.

(a) Put a clean copper wire in a test tube half full of mercuric chloride solution (POISON). After a short time remove the wire and observe the deposit.

(b) Proceed as in (a) with copper wire and a solution of lead nitrate. Note the deposit, if any.

(c) Proceed as in (a) using a strip of zinc and the solutions separately. Note the results.

*Write a very brief account of this exercise in your laboratory notes.*

*Write also a list of the metals in the order of their displacement by (1) copper and (2) zinc.*

### Exercise 62 — Flame Tests for Metals

MATERIALS. Sodium, potassium, calcium, and barium chlorides, strontium nitrate, metallic copper and zinc.

APPARATUS. — Test wire.

(a) **Review.** Recall or review the results of heating salts of the metals sodium, potassium, calcium, and barium on a clean test wire. If in doubt, predict the color and verify by tests.

(b) Heat a bit of strontium nitrate on a clean test wire in the flame, and note the color. Compare with the color due to calcium and note (1) the resemblance and (2) the difference. Decide upon a name for the strontium color.

(c) Heat a copper wire in the hot part of the Bunsen flame and note the color. Decide upon a name for it.

(d) As in (c), using a strip of zinc and taking care to tilt the burner so that melted zinc will not drop inside. Note the color. Compare with the color from copper. Decide upon a name for the color.

(e) Test unknowns and note the results.



Write the results of this exercise in your laboratory notes in this form : —

COMPOUND OR METAL	COLOR OF FLAME	COMPOUND OR METAL	COLOR OF FLAME
1.		6.	
2.		7.	
3.		8.	
4.		9.	
5.		10.	

## SUPPLEMENTARY EXERCISES ON METALS

### Supplementary Exercise 56 — Tests for Metals

**MATERIALS.** — For **A** aluminum sulfate or alum solution. For **B** copper sulfate and potassium ferrocyanide solutions, acetic acid. For **C** magnesium sulfate, ammonium chloride, and disodium phosphate solutions. For **E** mercuric chloride, mercurous nitrate, stannous chloride solutions. For **G** lead nitrate, hydrogen sulfide and potassium dichromate solutions. For **J** manganese sulfate and ammonium sulfide solutions. For **K** gold chloride and stannous chloride solutions.

Test “unknowns” for these metals.

**A. Aluminum.** — Add ammonium hydroxide to a solution of an aluminum salt (*e.g.* aluminum sulfate or alum), and shake well. The precipitate is aluminum hydroxide. Note its color and texture.

**B. Copper.** — (1) Add considerable ammonium hydroxide to a solution of a copper salt (*e.g.* copper sulfate), and shake well. Note the final solution, especially the color.

(2) To 5 cc. of dilute copper sulfate solution add a few drops of acetic acid and of potassium ferrocyanide solution. Note the precipitate (cupric ferrocyanide,  $\text{Cu}_2\text{Fe}(\text{CN})_6$ ), especially the color.

**C. Magnesium.** — To 5 cc. of a solution of a magnesium salt (*e.g.* magnesium sulfate) add *in succession* ammonium chloride, ammonium hydroxide, and disodium phosphate solutions. Note the precipitate (ammonium magnesium phosphate,  $\text{NH}_4\text{MgPO}_4$ ), especially the color and texture.

**D. Zinc.** — See **Supplementary Exercise 9**.

**E. Mercury.** — (1) Mercuric compounds. (a) To 5 cc. of dilute mercuric chloride solution (POISON) add a little ammonium hydroxide, shake well, and note the color of the precipitate.

(b) To 5 cc. of dilute mercuric chloride solution (POISON) add a little stannous chloride solution and note the precipitate; then add considerable stannous chloride solution and note the final result. The black precipitate is finely divided mercury.

(2) Mercurous compounds. (a) Proceed as in (1) (a), using mercurous nitrate solution, and note the difference, especially the color.

(b) Add dilute hydrochloric acid to mercurous chloride solution and note the color of the precipitate. Then add considerable ammonium hydroxide (to alkaline reaction — test with red litmus paper), shake well, and note the color of the final product.

**F. Tin.** — See **E** (1) (b).

**G. Lead.** — (1) Add a little hydrogen sulfide water to a solution of a lead salt (*e.g.* lead nitrate). Note the precipitate (lead sulfide, PbS), especially the color.

(2) As in (1), using dilute sulfuric acid.

(3) As in (1), using potassium dichromate solution.

**H. Silver.** — See **Exercise 26**.

**I. Chromium.** — See **G** (3).

**J. Manganese.** — (1) Add a little ammonium sulfide solution to a manganese salt (*e.g.* manganese sulfate) solution and note the precipitate (manganese sulfide, MnS), especially the color.

**K. Gold.** — Obtain a solution of gold chloride (or prepare it as in **Supplementary Exercise 23**). Heat the solution in the hood to drive off free chlorine and the nitric acid; dilute with water, and add slowly a little dilute stannous chloride solution. Note the purple (or black) precipitate of finely divided gold. If very dark, add considerable water and shake well.

*Write a brief statement of each test in your laboratory notes.*

## Supplementary Exercise 57 — Tests with Borax Beads

**MATERIALS.** — Powdered borax, cobalt nitrate, copper sulfate, and manganese sulfate solutions.

**APPARATUS.** — Test wire, lens.

Heat the looped end of a clean test wire (preferably platinum — see APPENDIX, § 5 (*d*)), and dip it into powdered borax. Heat the adhering borax in the flame, rotating the wire slowly, until no further change is apparent; continue to dip it into the borax and heat in the flame until a small bead is formed.

(*a*) **Cobalt Compounds.** — Moisten a borax bead with cobalt nitrate solution. Heat the bead in the oxidizing part of the Bunsen flame (Fig. 77 left); rotate the bead while

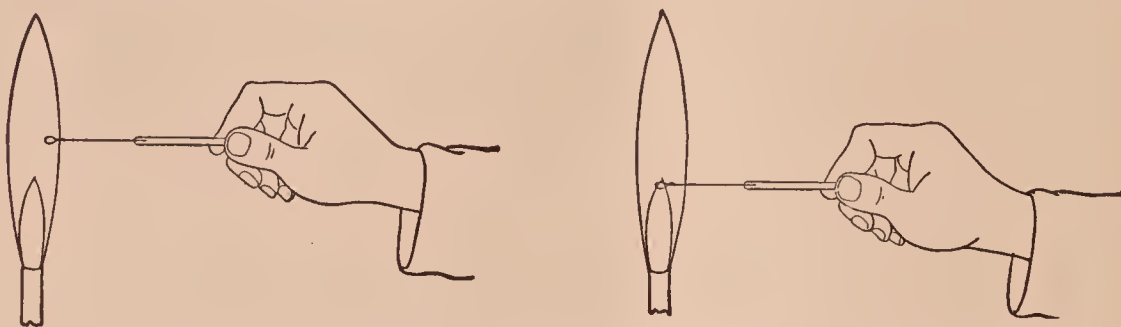

FIG. 77. — Testing with borax beads — oxidizing left, and reducing right

heating it. Note the color of the cold bead. If it is black, melt in a little more borax; if faintly colored, moisten again with the cobalt nitrate solution. The color is readily detected by looking at the bead against a white object in a strong light, or by examining it with a lens.

When the color has been definitely determined, heat the bead in the reducing flame (Fig. 77 right). Compare the color of the cold bead with the previous observation. Note the result.

Remove the bead from the wire by dipping it, while hot, into water and then rubbing or scraping it from the wire.

(*b*) **Copper Compounds.** — Make another bead and proceed as in (*a*), using copper sulfate solution. Compare the colors of the cold beads.

(*c*) **Manganese Compounds.** — Proceed as in (*a*) with another bead and manganese sulfate solution. Compare the colors of the cold beads.



Write the results of this exercise in your laboratory notes in tabular form, thus:—

NAME OF COMPOUND	COLOR OF COLD BEAD	
	Oxidizing Flame	Reducing Flame
(a)		
(b)		
(c)		
(d)		

### Supplementary Exercise 58 — Cobalt Nitrate Tests

**MATERIALS.** — Aluminum sulfate, magnesium sulfate, zinc sulfate, cobalt nitrate solution, charcoal block.

**APPARATUS.** — Blowpipe, blowpipe tube.

(a) **Aluminum.** — Heat a little aluminum sulfate (or any other aluminum compound) on charcoal in the blowpipe flame (oxidizing part — *A* in Fig. 68). Cool, and moisten with a drop or two of cobaltous nitrate solution. Heat again, and note the color of the residue on the charcoal.

(b) **Zinc.** — Proceed as in (a), using zinc sulfate (or any other zinc compound). Note the color of the residue.

(c) **Magnesium.** — Proceed as in (a), using magnesium sulfate. Note the color of the residue.

Write in your laboratory notes a brief statement of the cobalt nitrate tests for (a) aluminum, (b) zinc, and (c) magnesium.

### Supplementary Exercise 59 — Testing Salts for the Metal and Non-Metal

**MATERIALS.** — Chlorides, sulfates, carbonates, and nitrates of sodium, potassium, calcium, barium, and ammonium; bromide and iodide of potassium; nitrates of silver, lead, and mercury (ous); dilute hydrochloric acid.

Obtain several unknowns from the substances enumerated above and test separate portions of each for (a) the metal

part, *i.e.* sodium, potassium, calcium, barium, silver, lead, ammonium, and (b) the non-metal part, *i.e.* chloride, sulfate, nitrate, bromide, iodide, and carbonate. Note each result.

Write the results of this exercise in your laboratory notes in this tabular form : —

NUMBER OF SUBSTANCE	METAL PART	NON-METAL PART	NAME OF SUBSTANCE	FORMULA
1.				
2.				
Etc.				

### Supplementary Exercise 60 — Silver Salts and Photography — Teacher's Exercise

**MATERIALS.** — Solutions of silver nitrate (17 gm. to a liter), sodium chloride (5.8 gm. to a liter), and sodium thiosulfate — “hypo” (250 gm. to a liter); commercial developer or a substitute (see APPENDIX, § 13, LIST G).

**APPARATUS.** — 4 test tubes (labeled), black paper; for (f), 2 plates (preferably lantern slide plates), and photographic paper.

**NOTE.** — Owing to the rapid action of silver bromide, silver chloride is used in (a) to (d).

(a) Add 5 cc. of the silver nitrate solution to 5 cc. of the sodium chloride solution, shake gently, and note the time (by a watch). Expose the precipitate to the light. Examine frequently and note the time needed for a definite change in color.

(b) Precipitate silver chloride as in (a) and add also 5 cc. of the developer. Note the time. Expose and note the final time as in (a). Compare the times needed for the change.

(c) Wrap a piece of dark paper around a test tube to protect it from the light, and add the three solutions as in (b). After half a minute, examine quickly and note the color. Examine again after half a minute more. Compare with (b).

(d) Precipitate silver chloride as in (a), add also 5 cc. of “hypo” solution, and shake well. Note the result.

(e) Optional. Try (a) to (d) with silver bromide (prepared from dilute silver nitrate and potassium bromide solutions) and compare the results with (a) to (d).

(f) Expose two photographic plates (preferably lantern slide plates) or films, develop both in the dark room with the class, fix one, and later compare both. Make two prints from the fixed plate, and develop. Wash one, and later compare the two prints.

*Write an account of this exercise ((a) to (d)) in your laboratory notes.*

*Write also the results of (e) and (f), if done.*

### **Supplementary Exercise 61 — Preparation and Properties of Aluminum Hydroxide**

**MATERIALS.** — Solutions of aluminum sulfate, sodium hydroxide, cochineal, and aluminum acetate; turbid water, alizarin paste, cotton cloth.

(a) Add 5 cc. of ammonium hydroxide to 5 cc. of aluminum sulfate solution, shake, and note the precipitate of aluminum hydroxide.

(b) To 5 cc. of aluminum sulfate solution (1) add a very little sodium hydroxide, shake, and note the result, and then (2) add considerable sodium hydroxide, shake, and note the result.

(c) Fill a test tube half full of turbid water (prepared by shaking fine clay with water), add 5 cc. of aluminum sulfate solution, shake well, add 10 cc. of ammonium hydroxide solution, and mix well by stirring. Let the mixture stand about ten minutes, and then compare the upper part of the liquid with the sample of turbid water. Note the difference.

(d) Add a little aluminum sulfate solution to a dilute solution of cochineal, then add ammonium hydroxide, and shake well. Filter, and compare the colors of the filtrate and precipitate.

(e) Boil two small pieces of cotton cloth for several minutes thoroughly in water. Remove the excess of water. (1) Put one piece in a dish or beaker, add 50 cc. of water and



5 cc. of alizarin paste, and heat nearly to the boiling point for about two minutes. Wash the cloth in water, dry, and then examine. (2) Proceed in the same way with the other piece of cotton cloth which has been previously mordanted by boiling for about two minutes in aluminum acetate solution. Compare the two pieces of cloth as to color.

*Write answers to these questions in your laboratory notes.*  
(1) *What is a conspicuous property of aluminum hydroxide?*  
(2) *What are the equations for (a) and (b)?* (3) *What is a test for aluminum hydroxide?* (4) *Of what value is aluminum hydroxide (a) as a water purifier and (b) in dyeing?*

### Supplementary Exercise 62 — Qualitative Analysis of a Solution of Lead, Silver, and Mercury (ous)

**MATERIALS.** — Solution containing lead nitrate, silver nitrate, and mercurous nitrate; hydrogen sulfide water, potassium chromate solution.

(a) **Precipitation.** To 10 cc. of the solution containing the three metals (as the ions  $\text{Pb}^{++}$ ,  $\text{Ag}^+$ ,  $\text{Hg}^+$ ) add dilute hydrochloric acid drop by drop until precipitation ceases.

(b) **Separation of Lead.** Allow the mixture of precipitated chlorides to settle, pour off the liquid carefully, add about 15 cc. of water, boil, and filter. This operation dissolves most of the lead chloride. Test the filtrate for lead as in (c); save the precipitate for (d).

(c) **Test for Lead.** To separate portions of the filtrate add hydrogen sulfide water and potassium chromate solution. The two solid products are lead sulfide and lead chromate. Note the color of each precipitate.

(d) **Separation of Silver and Mercury.** Wash the precipitate from (b) with hot water until the wash water does not give a test for lead. Then stand the funnel in a clean test tube and pour ammonium hydroxide on the mixture of silver and mercurous chlorides. This operation dissolves the silver chloride. Test the filtrate as in (e); save the precipitate for (f).

(e) **Test for Silver.** To the filtrate from (d) add dilute nitric acid to acid reaction and shake. The dissolved silver compound is decomposed and the silver is precipitated as silver chloride.

(f) **Test for Mercury.** The black residue on the paper in (d) is a sufficient test for mercury. Confirm thus: Pour a little *aqua regia* (mixture of 3 cc. of concentrated hydrochloric acid and 1 cc. of concentrated nitric acid) upon the black precipitate; catch the filtrate in a porcelain dish, dilute with about 5 cc. of water, and add a clean copper wire; remove the wire in a few minutes, and mercury will be seen on the wire as a bright silvery coating.

*Write in your laboratory notes a very brief outline of the steps in this exercise.*

*Write also the three equations for (a) and the two for (c).*

*Write also from this exercise the test for  $Pb^{++}$ ,  $Ag^+$ , and  $Hg^{++}$ .*





## APPENDIX

1. The pressure of water vapor in millimeters of mercury is : —

TEMPERATURE	VAPOR PRESSURE	TEMPERATURE	VAPOR PRESSURE	TEMPERATURE	VAPOR PRESSURE
12	10.5	17	14.4	22	19.7
12.5	10.8	17.5	14.9	22.5	20.3
13	11.2	18	15.4	23	20.9
13.5	11.6	18.5	15.9	23.5	21.5
14	11.9	19	16.4	24	22.2
14.5	12.3	19.5	16.9	24.5	22.8
15	12.7	20	17.4	25	23.6
15.5	13.1	20.5	18.0	25.5	24.3
16	13.6	21	18.5	26	25.0
16.5	14.0	21.5	19.1	26.5	25.7

The numbers in the Vapor Pressure columns are the values for  $a$  in the formula for the reduction of gas volumes : —

$$V = \frac{V'(P' - a)}{760(1 + (0.00366 \times t))}$$

2. **How to use the Bunsen burner.** — The Bunsen burner (Fig. I) is used as a source of heat. It is attached to a rubber tube (A), which should be connected with the gas supply. To light the burner, turn on the gas and hold a lighted match a short distance above the top of the burner tube (B). The flame usually used should have a faint blue color. If it is yellow, turn the ring at the bottom of the burner until the flame is blue.

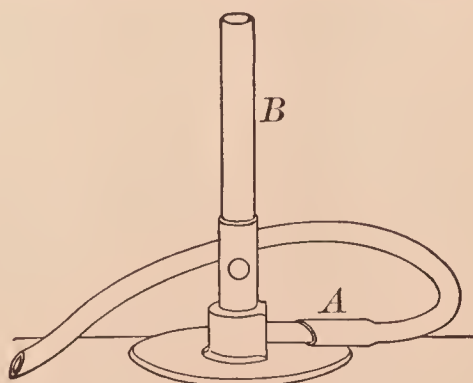

FIG. I. — Bunsen burner

A flame of suitable height for most experiments is about 10 centimeters (or 4 inches). Adjust the gas pressure until the

flame is about this height. The hottest part of the flame is near the top.

In heating with the Bunsen burner follow these directions:—

(a) Light the burner before a piece of apparatus is held over it or before it is placed beneath a wire gauze which supports a dish or a flask.

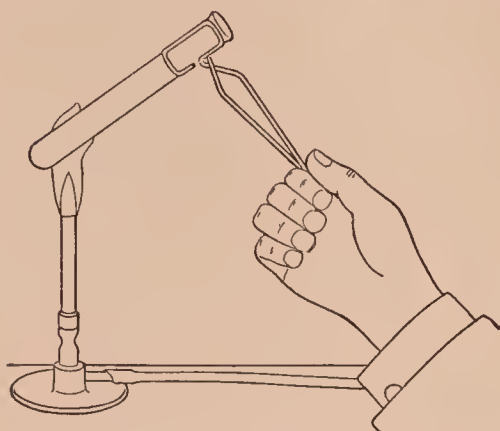

FIG. II. — Using a test tube holder

(b) Test tubes — used frequently — should be dry on the outside. As a rule the test tube should be attached to a test tube holder and held at an angle, as in Fig. II. If the test tube contains a solid, heat gradually by moving the tube in and out of the flame. If the test tube contains a liquid, only

the part containing the liquid should be put in (or above) the flame. When the liquid begins to boil, the test tube should be removed from the flame for an instant or held over it.

(c) Do not heat *empty* glass apparatus, *e.g.* beakers. In heating a beaker containing a liquid, do not use the free flame, but place the vessel on a wire gauze which stands on an iron ring. Porcelain dishes should also be placed on a gauze. Porcelain crucibles may be heated with a free flame as directed. All glass and porcelain apparatus should be heated and cooled gradually.

### 3. Cutting, bending, drawing, and closing glass tubing. —

(a) **Cutting.** — Determine the length needed, lay the tube on the desk, and with forward strokes of a triangular file make a short, deep scratch where the tube is to be cut. Grasp the tube in both hands, and hold the thumbs together *opposite* the scratch; now push gently

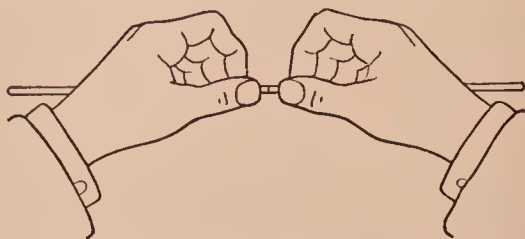

FIG. III. — Cutting a glass tube

with the thumbs, pull at the same time with the hands, and the tube will break at the desired point (Fig. III). The sharp ends should be smoothed by rotating them

slowly in the Bunsen flame until a yellow color is distinctly seen or until the end becomes red hot; this operation is called fire polishing (Fig. IV).

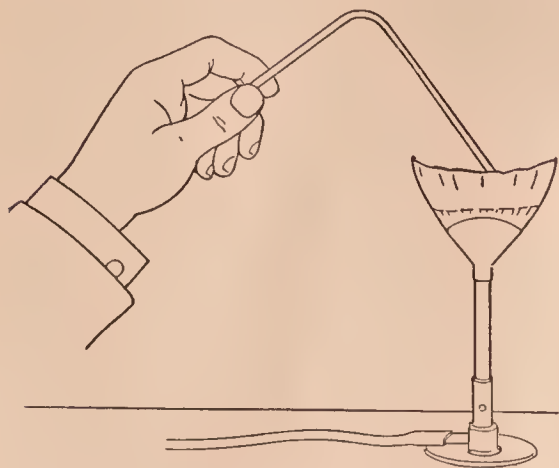

FIG. IV. — Fire polishing a glass tube

Slip the wing-top upon the top of the burner tube before lighting the gas. The flattened Bunsen flame should be slightly yellow and about 7 centimeters (2.5 inches) wide for ordinary bends.

A **right-angle bend** is easily made. Determine the part where the tube is to be bent.

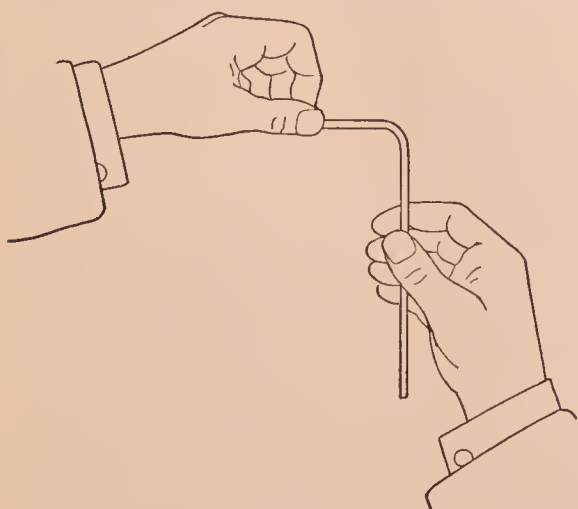

FIG. VII. — Bending a tube into a right angle — second step

(b) **Bending.** — Glass tubes can be bent in an ordinary



FIG. V. — A wing top

illuminating gas flame, but if the Bunsen flame is used, it should be flattened by a wing-top attachment (Fig. V).

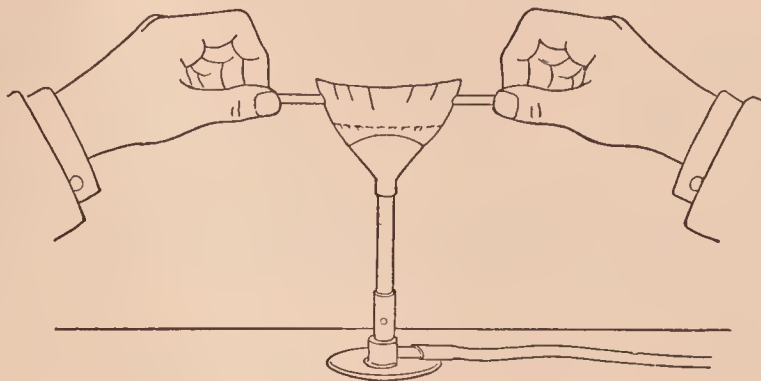

FIG. VI. — Bending a tube into a right angle — first step

Grasp the tube in both hands, and hold it so that this part is directly over the middle of the flame (Fig. VI). Slowly rotate it between the thumbs and forefingers, and gradually lower it into the flame. Continue to rotate it until the glass feels soft and ready to bend. Then remove it from the flame, and slowly bend it into a right angle (Fig. VII). Use a square block of wood to assist the eye in



making an exact right angle. The bent part of the tube can be annealed (to prevent cracking) by rotating it in a yellow flame until it becomes coated with soot, and then allowing it to cool slowly.

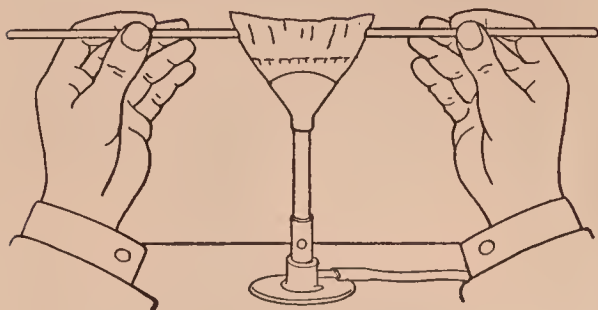

FIG. VIII. — Bending a tube into an oblique angle — first step

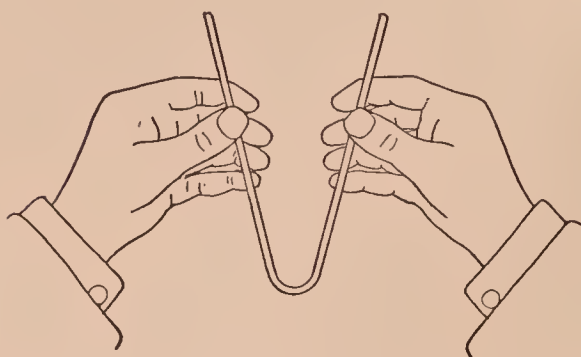

FIG. IX. — Bending a tube into an oblique angle — second step

A tube can be bent into a **small oblique angle** by heating it through about twice the space required for a right angle (Figs. VIII, IX). A **large oblique angle** (*i.e.* a very slight bend) can be made by holding the tube across the flame, heating a short space, and then bending slightly.

(c) **Drawing.** — Glass tubes can be drawn into two pointed tubes thus: Heat the tube as in (b) through about 2.5 centimeters (1 inch) of its length, re-

move it from the flame and slowly pull it apart a short distance; let it cool for a second or two, and then pull it quickly to the desired length.

By using a glass rod, **stirring rods** can be made in the same way, but the rod must be heated for a longer time than the tube.

(d) **Closing.** — Glass tubes can be closed by holding the end in the flame and slowly rotating the tube until the glass melts and closes the end. If both ends are to be closed (as in making the glass plug for **Exercise 27**), close one end, then draw out the other end, melt off the shorter piece, and thicken the remaining end by heating and rotating in the flame.

**4. Filtering.** — A liquid may be separated from a solid by filtering. A circular piece of filter paper (Fig. X — A) is folded to fit a glass funnel, and when the mixture is poured upon this paper the solid — called the residue or **precipitate** —

is retained, while the liquid — called the **filtrate** — passes through and may be caught in a test tube or any other vessel.

Sometimes the clear liquid is first poured carefully off from the precipitate (or other solid) without disturbing the solid (see Fig. XIV). This operation is called **de-canting**, and sometimes precedes a final filtering.

The filter paper is prepared for the funnel by folding the circular piece *A* (Fig. X) into the shapes *B* and *C*. The folded paper is then opened into the

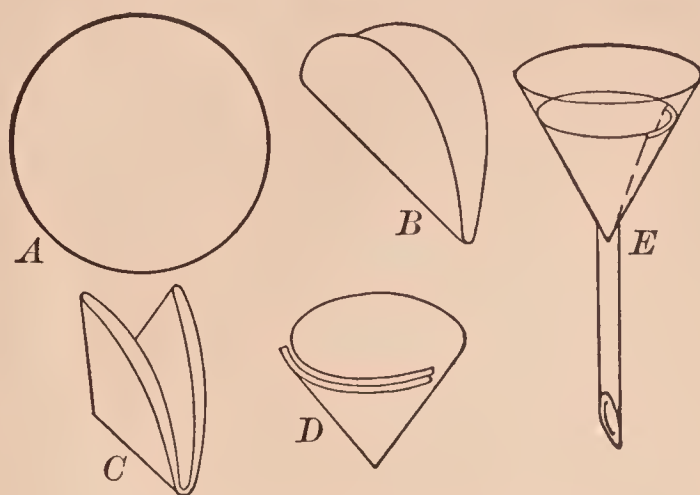

FIG. X. — Folding a filter paper

cone *D* so that three thicknesses are on one side and one on the other. **To filter**, the cone-shaped paper (*D*) is placed in the funnel *E* and moistened with water, so it will stick to the funnel. The liquid to be filtered may be poured directly from the vessel upon the paper or down a glass rod

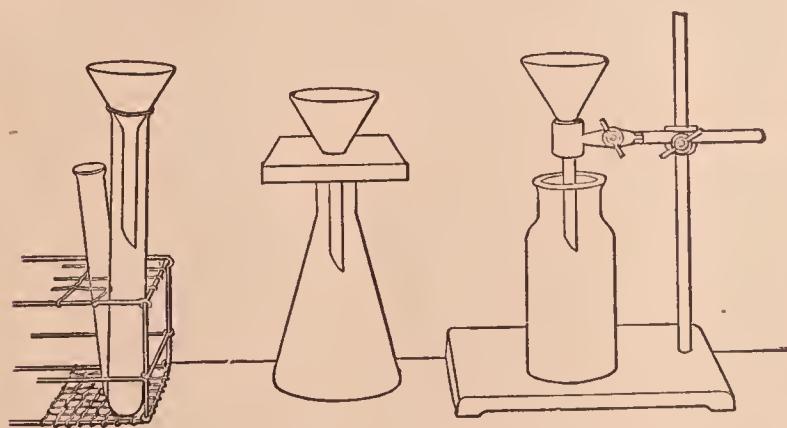

FIG. XI. — Funnel supported for filtering

(Fig. XIV) which touches the edge of the vessel (§ 6 (*a*) below); the lower end of the rod should nearly touch the paper inside the funnel. The funnel can be supported as shown in Fig. XI.

**5. Constructing and arranging apparatus.** — The various parts of the apparatus should be assembled and put together as completely as possible before starting the exercise. The parts that are to fit each other should be connected so that all joints are gas-tight. In long exercises or those involving weighing, the apparatus should be inspected by the Teacher.

The following directions should be studied carefully: —

(a) **To insert a glass tube into a rubber tube.** — Cut one end of the rubber tube at an angle, moisten the smoothed end of the glass tube with water, place the end of the glass tube in the angular-shaped cavity so that both tubes are at about a right angle, grasp the upper end of the rubber tube firmly and slip it slowly down and over the end of the glass tube.

(b) **To push a glass tube through a hole in the stopper.** — Dip the stopper in water or wet one end of the tube and grasp it firmly near this end; hold the stopper between the thumb and forefinger of the other hand, and carefully work the tube through the hole by a gradual rotary motion. *Never* point the tube toward the palm of the hand that holds the stopper. *Never* grasp a bent tube at the bend when inserting it into a stopper — it may break and cut the hand severely.

(c) **To bore a hole in a cork.** — Select a cork free from cracks or channels and use a borer which is one size smaller than the desired hole. Moisten the borer with water or soap solution. Hold the cork between the thumb and forefinger, press the larger end against a firm board, and slowly push the borer by a rotary movement through the cork, taking care to bore perpendicularly to the cork (Fig. XII). If the hole is too small, enlarge it with a round file. Push the small cylinder of cork finally out of the borer with the handle.

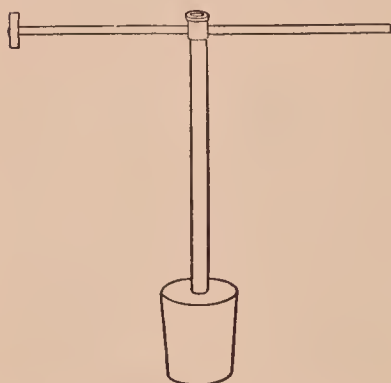

FIG. XII. — Cork borer in a cork

(d) **To make a test wire.** — (1) **Platinum.** Cut the glass rod and wire to the desired length — about 10 centimeters (4 inches) and 7 centimeters (3 inches) respectively. Rotate one end of the rod in the flame until it softens. At the same time grasp the platinum wire firmly in the forceps about 1 centimeter (0.5 inch) from the end, and hold it also in the

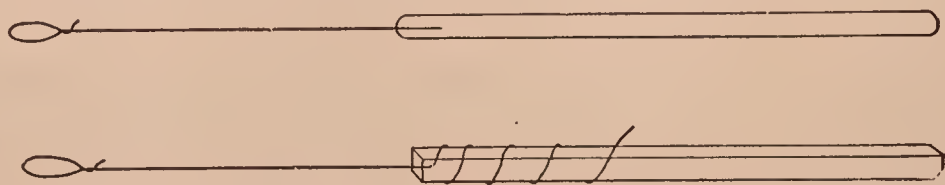

FIG. XIII. — Test wires — platinum (upper), nichrome (lower)



flame. When the rod is soft enough, gently push the hot end of the wire into the rod.

(2) **Nichrome.** Wind a piece of nichrome wire around a match stick. The completed test wires are shown in Fig. XIII.

**6. Pouring liquids and transferring solids.** — (a) Liquids can be poured from a test tube or dish without spilling by moistening a glass rod with the liquid, holding the wet rod against the edge of the vessel, and then pouring the liquid slowly down the rod (Fig. XIV).

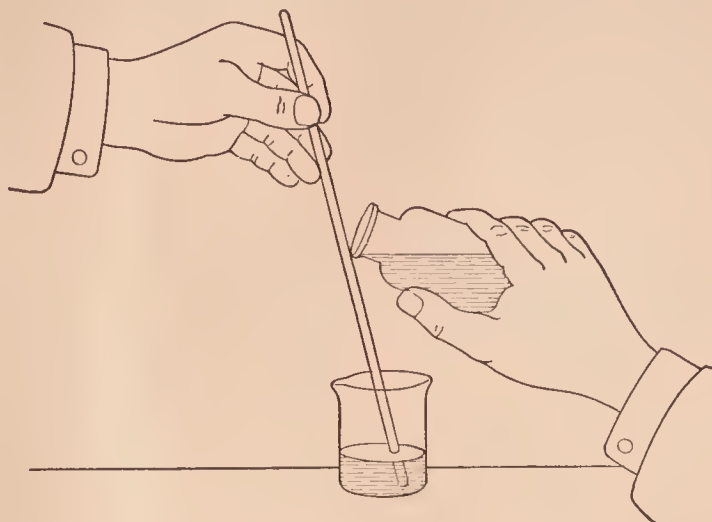

FIG. XIV. — Pouring a liquid down a rod

(b) Liquids should be poured from a bottle by holding the bottle as shown in Fig. XV. Note that the stopper and bottle are held in the same hand. The stopper is first removed by holding the palm of the hand upward and grasping the stopper between the fingers before the bottle is lifted

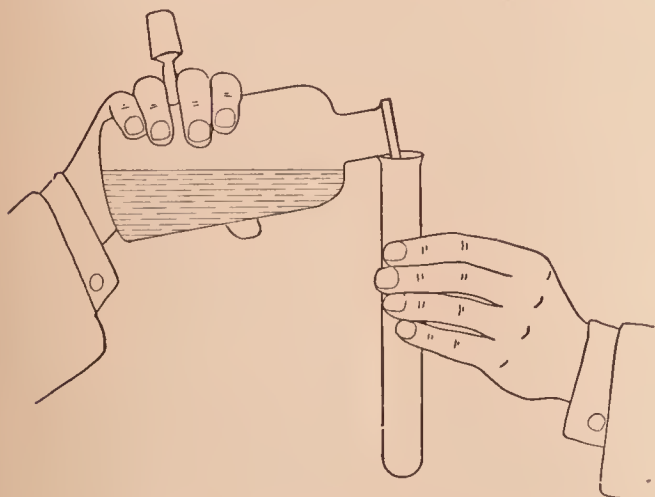

FIG. XV. — Pouring a liquid from a bottle

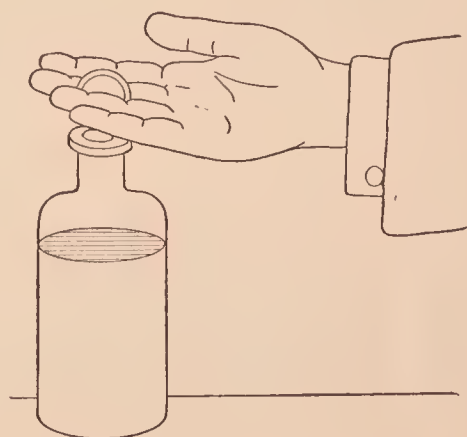

FIG. XVI. — Removing the stopper from a bottle

(Fig. XVI). All stoppers should be removed this way when possible, and held between the fingers — not laid down on the desk. The drop on the lip of the bottle should be touched with the stopper before the latter is put back into the bottle.

(c) Solids should never be poured directly from a large bottle into a test tube or dish. Use a spoon, spatula, or piece of smooth paper; or rotate the bottle slowly so that the solid

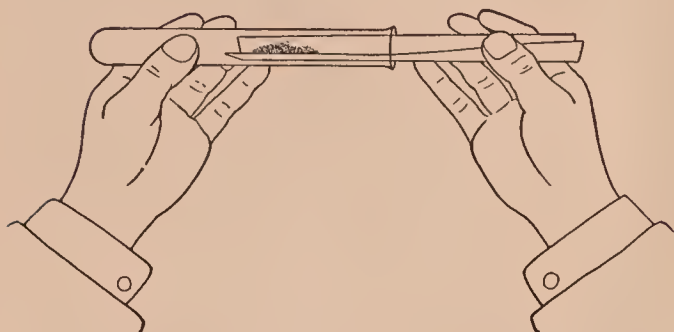

FIG. XVII. — Putting a solid into a tube — first step

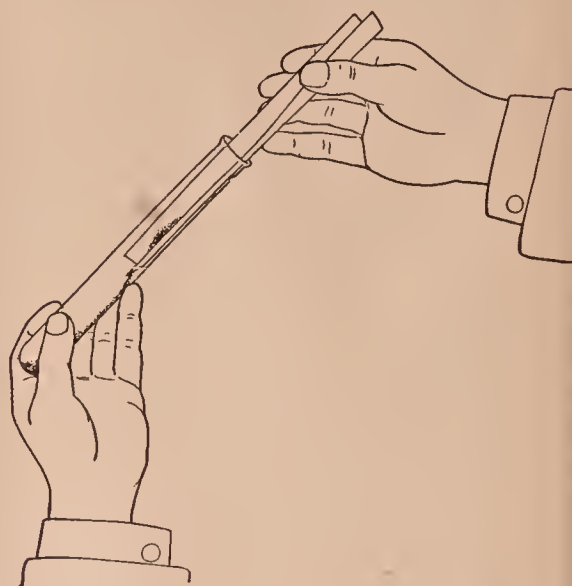

FIG. XVIII. — Putting a solid into a tube — second step

will roll out in small quantities. If the solid is very fine or dirty (*e.g.* mercuric oxide or charcoal), catch the solid on a narrow strip of paper creased lengthwise, and introduce the solid from the paper into the test tube as shown in Figs. XVII, XVIII.

**7. Collecting gases.** — Gases are usually collected over water in a pneumatic trough; one form is shown in outline in

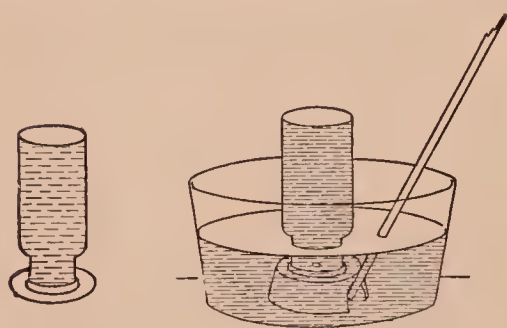

FIG. XIX. — Pneumatic trough in outline (right); bottle of water covered and inverted (left)

Fig. XIX (right). The bottle (or tube) to be filled with gas is first filled with water, covered with a piece of filter paper, inverted (Fig. XIX — left), and placed mouth downward on the support of the trough, which is previously filled with water just above the support (Fig. XIX — right). The paper is then removed. Glass plates instead of

filter paper may be used to cover the bottle, but of course such covers must be held on when the bottle is inverted and placed on the support.

The gas escapes from the delivery tube, bubbles up through the water into the vessel, and forces the water out of the vessel. Gases not very soluble in water (*e.g.* oxygen and hydrogen) are collected in this way.

Some soluble gases, *e.g.* hydrochloric acid, chlorine, and sulfur dioxide, are collected by allowing the gas to flow downward into an empty bottle, *i.e.* by downward displacement, while ammonia and other light gases are collected by allowing the gas to flow upward into a bottle, *i.e.* by upward displacement.

**8. Weighing.** — Weighing may be approximate or accurate. **Approximate weighings** are made on the scales (Fig. XX); **accurate weighings** are made on the horn pan balance (Fig. XXI) or on the chemical balance (Fig. XXII). The **metric system of weights** is used in chemistry and should be studied before weighing is attempted. (See § 10 below.)

Note these general directions about weighing: —

(1) Before weighing, see that the scales and balances are clean and properly adjusted. If out of order, do not adjust them yourself, but report to the Teacher.

(2) Put objects on the left side and weights on the right. Large (or heavy) objects and weights should be put near the center of the pan.

(3) Substances should not be placed directly on the platform or pan, except pieces of certain metals, *e.g.* zinc or aluminum, or porcelain and glass objects.

In weighing on the scales, put a piece of paper of about

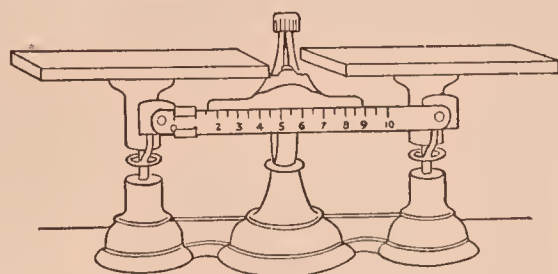

FIG. XX. — Scales

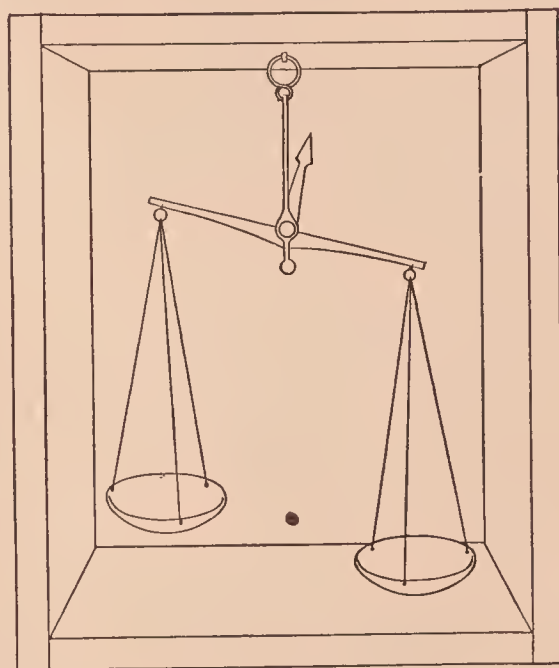

FIG. XXI. — Horn pan balance hanging in a box (open in front and closed in back) to protect balance from air currents



equal size on each platform; the paper on the left should be creased. Take the substance from the bottle with a clean spoon or spatula, or pour it out by rotating the bottle as described in § 6 (c) above; if too much is taken out, do not put it back into the bottle, but throw it into the waste jar or a special bottle. Approximate weighings are made on the scales, *e.g.* the quantities of chemicals usually needed in ordinary exercises. Very often, small quantities need not be

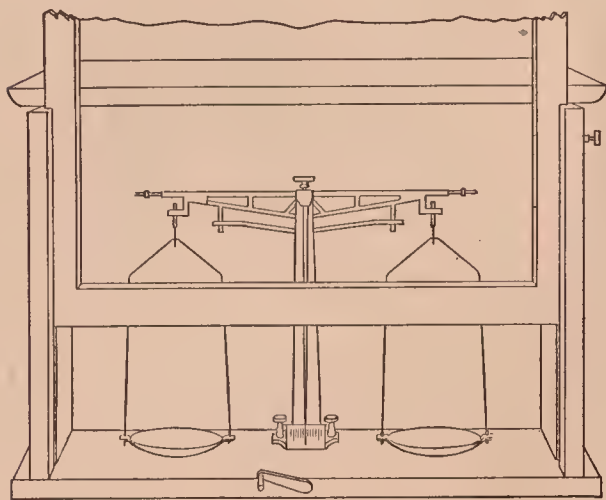

FIG. XXII. — Chemical balance in a glass case (front partly raised)

weighed because the quantity can be estimated by the eye. Objects and quantities weighing over 100 gm. should be weighed on the scales (follow directions).

In weighing on the horn pan or the chemical balance, if the substance itself should not be placed directly on the pan, weigh a small watch crystal or cru-

cible and then weigh the substance in this vessel. Sometimes a piece of apparatus is hung from the balance hook. Accurate weighings are made on the balance, *e.g.* the exact quantities needed in quantitative exercises. Enter the total weight at once in the proper place in the RECORD in the laboratory notebook — not on a scrap of paper. Enter the weight as grams and a decimal fraction, *e.g.* 5.29 grams, not 5 grams, 2 decigrams, and 9 centigrams. Enter *all* weighings — temporary and final — in the notebook.

The process of weighing is as follows: —

**A. Scales.** — Put the object, or the paper containing the proper substance, on the left side; on the right side put one or more weights which are judged to be the approximate weight. Now add or remove (substance or) weights until the pointer swings the same number of spaces each side of the middle division. Weighings of small quantities, *e.g.* 5 grams or less, are usually made by sliding a rider along a graduated beam on the front of the scales.

**B. Chemical balance.** — Release the beam by turning the screw or lever. The pointer should swing the same (or very nearly the same) number of spaces each side of the central line. If it does not, consult the Teacher. If it does, proceed with the weighing. Put the object (*e.g.* crucible, dish, tube, or special substance) on the left pan and the weight judged to be equal on the right pan. Release the beam carefully by turning the screw or lever, and note the movement of the pointer. If the added weight is correct, the pointer will swing the same (or very nearly the same) number of spaces each side of the central line on the scale. If incorrect (as it usually is), slowly turn back the screw or lever and bring the balance to rest. Add or remove the weight which is next heavier or lighter — as needed — and release again. If not correct, bring the balance to rest, and change the weights accordingly, taking care to add or remove the weights in order (*i.e.* next heavier or lighter). Continue to change the weights, bringing the balance to rest each time, until the correct weight is obtained, *i.e.* when the pointer swings the same number of spaces each side of the central line as it did at the beginning. As soon as the substance or object is weighed, note the weights on the pan and record their sum at once in the notebook, then compare the weights with those missing from the box; if correct, so indicate in the notebook, and finally check the total weight by adding the weights as they are returned to the box.

The following rules should be rigidly observed in weighing on the balance: —

(a) Always bring the balance to rest before changing the weights, the object, or the substance.

(b) If on releasing, the beam does not swing, arrest and release again, or fan one pan *very gently*.

(c) Lift all weights with clean forceps — not with the fingers (Fig. XXIII).

**C. Horn pan balance.** — The horn pan balance must be counterpoised before each weighing. This is readily done. Clean the pans with soft paper or cheesecloth. Allow them to swing freely and note which side is lighter by estimating the distances the pointer swings to right and left. Add bits of

wire or compact wads of paper to the proper pan until the balance is counterpoised, *i.e.* until the pointer swings equal distances to the right and left. Sometimes the balance can be more or less permanently counterpoised by pasting

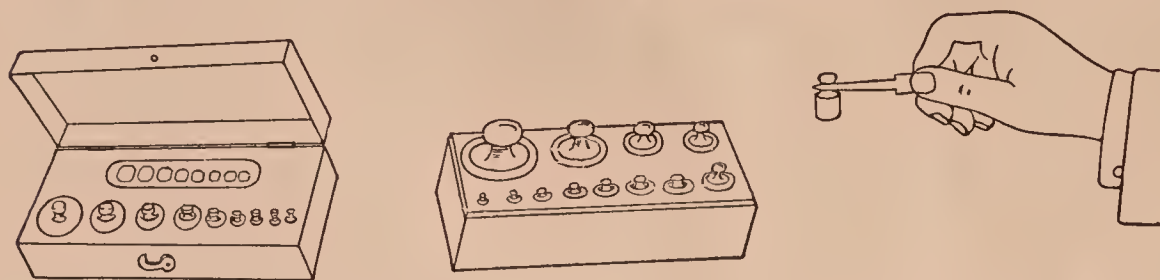

FIG. XXIII. — Weights for chemical balance (left) and scales (middle).  
Correct way of lifting weights (right)

small pieces of paper on the under side of one pan. Proceed with the weighing as in **B** (noting that there is no releasing screw).

**9. Measuring.** — Liquids are measured accurately in graduated cylinders and burettes (frontispiece *DD*). The lowest point of the curved surface of the liquid, called the **meniscus**, is its correct height.

Time can be saved by *learning and remembering* that the average ordinary test tube ( $15 \times 1.8$  centimeters or  $6 \times \frac{3}{4}$  inch) holds about 30 cc. (cubic centimeters), while the large test tube ( $20 \times 2.5$  centimeters or  $8 \times 1$  inch) holds about 75 cc. (cubic centimeters).

**10. The metric system.** — This system of weights and measures is used almost exclusively in chemistry, and should be learned, or reviewed, at once.

The fundamental unit of this system is the **meter**. It is the unit of length and is 39.37 inches long. The meter and the other units have multiples and submultiples, which are designated by prefixes attached to the particular unit. Thus, kilo- is equivalent to 1000, and deci-, centi-, and milli- to 0.1, 0.01, and 0.001. Thus: —

$$\begin{aligned} 10 \text{ millimeters (mm.)} &= 1 \text{ centimeter (cm.)} \\ 10 \text{ centimeters} &= 1 \text{ decimeter (dm.)} \\ 10 \text{ decimeters} &= 1 \text{ meter (m.)} \end{aligned}$$

In chemistry, the measures of length usually used are the millimeter (mm.) and centimeter (cm.); occasionally the



meter (m.) is used. For example, the normal height of the barometer is 760 mm. or 76 cm., the length of tubing used in experiments is given in centimeters, and of long pieces of apparatus in meters (and a decimal fraction). A comparative scale is given in Fig. XXIV. Note that 2.5 cm. = 1 in. (very nearly).

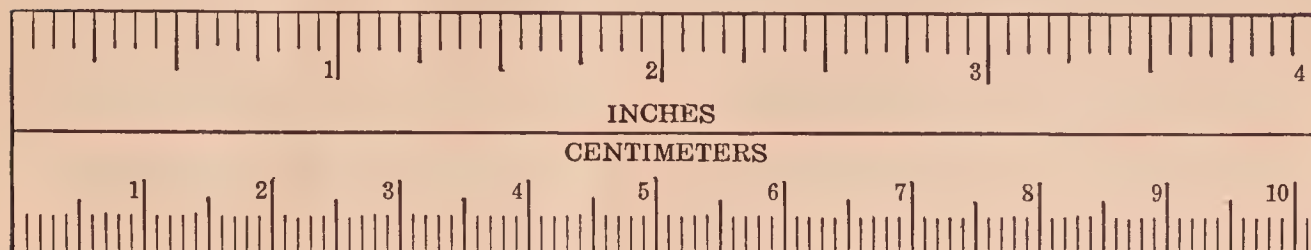

FIG. XXIV. — Comparative scale — metric below, English above. On the metric scale the numbered divisions are centimeters and the smallest are millimeters

The unit of weight is the **gram**. It is the one-thousandth part of a standard weight called the **kilogram**. Thus: —

10 milligrams (mg., mgm.) = 1 centigram (cg.)

10 centigrams (cg.) = 1 decigram (dg.)

10 decigrams (dg.) = 1 gram (gm.)

1000 grams (gm.) = 1 kilogram (kg.)

A kilogram weighs about 2.2 pounds (avoir.). Large weights are often expressed in kilograms (and a decimal fraction). A gram weighs 15.43 grains. Small weights are expressed in grams. Thus, the weight of an object weighing 2 grams, 2 centigrams, and 5 milligrams is written, 2.025 grams (or gm.).

The unit of volume is the **liter**. It is equal to the capacity of the vessel containing a kilogram of water. A liter equals about one quart. The table is: —

1000 cubic millimeters = 1 cubic centimeter (cc.)

1000 cubic centimeters = 1 cubic decimeter (cu. dm.)

1 cubic decimeter = 1 liter (l.)

In chemistry the cubic centimeter and the liter are the denominations used to measure and express volume. Thus, a test tube measuring  $15 \times 1.8$  cm. holds about 30 cc., a large tube ( $20 \times 2.5$  cm.) holds about 75 cc., and the large test greenish glass acid bottles hold 2.5 l.

An approximate relation (true only in the case of water and liquids of the same specific gravity) is 1 l. = 1 kg. = 1 cu. dm. = 1000 cc. = 1000 gm. = 2.2 lb.

**11. Smelling and tasting.** — Unfamiliar substances should never be smelled or tasted except according to directions, and even then with the utmost caution. Never inhale a gas vigorously, but waft it gently with the hand toward the nose. Never ask another pupil to inhale a gas. Taste acids, bases, and salts by touching a minute portion of the *dilute* solution to the tip of the tongue, and as soon as the sensation is detected, reject the solution at once — never swallow it.

**12. Accidents.** — **Cuts**, even if slight, should be washed in clean, cold water, sterilized with dilute iodine solution, and then covered with collodion if slight, or bandaged if severe.

**Burns** should be covered with a paste made by mixing sodium bicarbonate (baking soda) and carron oil (an emulsion of limewater and oil) and then bandaged.

Acids and alkalies if spilled on the hands or spattered on the face should be washed off at once with water; if a burn is produced, this may be treated as described above.

**Fires** may be extinguished by sand or by a pyrene extinguisher. If the clothing catches fire, a damp towel or asbestos blanket should be used at once.

A portable **emergency box**, or cabinet, containing “first aid” articles should be kept in a convenient place. For contents, see APPENDIX, § 13, LIST F.

**13. Laboratory equipment.** — These lists include the apparatus, chemicals, and supplies needed for the exercises in this book. No allowance is made for breakage, duplicate corks and rubber stoppers, and extra glass and rubber tubing.

LIST A. — INDIVIDUAL OUTFIT. This list includes the articles needed by each pupil for the regular exercises.

1 Blowpipe.	1 Crucible and cover, porcelain, No. 0.
1 Blowpipe tube.	1 Crucible block, wood, 10 × 10 × 2.5 cm. with 3 cm. hole in center.
5 Bottles, wide mouth, 250 cc.	1 Deflagrating spoon.
1 Bottle, generator, 250 cc.	1 Evaporating dish, 7 cm.
1 Bunsen burner.	
1 Cork to fit small test tube.	
1 Cork to fit large test tube.	

- |  |  |
|--|--|
| 100 Filter papers, 10 cm.  | 1 Rubber tube, $\frac{3}{16}$ in. diam., 15 cm. long (for connectors).   |
| 1 Flask, Erlenmeyer, 250 cc.   | 1 Rubber tube, pressure ( $\frac{3}{16}$ in. diam.), 15 cm. long (for dropping funnel — Exer. 7). <sup>2</sup> |
| 1 Forceps, iron.   | 1 Sponge.  |
| 1 Funnel, 65 mm.   | 12 Test tubes, 15 × 1.8 cm. ( $6 \times \frac{3}{4}$ in.) (“small” test tube).                                 |
| 4 Glass plates, 10 × 10 cm.  | 3 Test tubes, 20 × 2.5 cm. ( $8 \times 1$ in.) (“large” test tube).  |
| 1 Glass rod, 15 cm.  | 1 Test tube brush.   |
| 1 Glass tube, 150 cm. <sup>1</sup>   | 1 Test tube holder.  |
| 1 Graduated cylinder, 25 cc.   | 1 Test tube rack.  |
| 1 Iron stand, clamp (medium), ring (8 cm.).                                | 1 Test wire — platinum 7 cm. or nichrome 10 cm. (see APP., § 5 (d)).   |
| 1 Matches (box).   | 1 Thistle tube, straight stem. <sup>2</sup>  |
| 1 Mortar and pestle, 8 cm.   | 1 Triangle. <sup>5</sup>   |
| 1 Pinch-clamp, Mohr's. <sup>2</sup>  | 1 Wire gauze, 10 × 10 cm.  |
| 1 Pneumatic trough, complete. <sup>3</sup>                                 | 2 Wooden blocks, 15 × 15 × 2.5 cm.   |
| 1 Rubber stopper, 23 mm., 1-hole. <sup>4</sup>                             |  |
| 2 Rubber stoppers, 23 mm., 2-hole. <sup>4</sup>                            |  |
| 1 Rubber tube, 6 mm. ( $\frac{1}{4}$ in.) diam., 60 cm. long (for burner). |  |

LIST B — SPECIAL APPARATUS. This list includes the special apparatus needed for a class of ten. Numbers in parentheses refer to exercises. Refer to the exercises and buy only the apparatus needed.

- |   |                                       |
|---|---------------------------------------|
| 1 Balance, chemical (4, 18, 22, 41).          | 2 Burettes, 50 cc. (30).              |
| 3 Balances, horn pan (as above). <sup>6</sup> | 1 Burner, gas (50).                   |
| 1 Barometer (20, etc.).                       | 3 Chimneys, lamp (S 25).              |
| 2 Beakers, 250 cc. (30).                      | 1 Cork borers, set (APP., § 5 (c)).   |
| 5 Bottles, 2500 cc. (41).                     | 1 Cylinder, graduated, 1000 cc. (21). |

<sup>1</sup> To fit the rubber stoppers.

<sup>2</sup> See Exercise 7. The stem of the thistle tube should fit the rubber stoppers.

<sup>3</sup> Preferable kind is an indurated fiber Keeler No. 4 provided with a shallow flower pot 10 cm. in diameter. An agateware pan may be used.

<sup>4</sup> To fit the large test tube. This size (about 23 mm.) also fits the average 250 cc. Erlenmeyer flask, the 250 cc. generator bottle, and the 2500 cc. bottle (acid bottle — See LIST B).

<sup>5</sup> To fit porcelain crucible.

<sup>6</sup> A chemical balance costing about twenty-five dollars is sufficiently accurate. Horn pan balances, if carefully counterpoised, give acceptable results. (See APP., § 8.)



- |   |   |
|---|---|
| 2 Cylinders, graduated, 500 cc. <sup>1</sup>              | 1 Scales (APP., § 8) (constantly).                              |
| 2 Cylinders, graduated, 250 cc. <sup>1</sup><br>(27, 45). | 5 Screws, Hofmann (41).   |
| 2 Cylinders, graduated, 100 cc. <sup>1</sup>              | 3 Thermometers, — 10° to 100° C. <sup>3</sup>                   |
| 1 File, round (APP., § 5 (c)).                            | 5 Tubes, graduated, 100 cc. (21).                               |
| 1 File, triangular (APP., § 3 (a)).                       | 1 Weights for chemical balance,<br>2 mg. to 50 gm. <sup>4</sup> |
| 1 Hydrometer (heavy) (45).                                | 3 Weights for horn pan balance,<br>2 mg. to 50 gm. <sup>4</sup> |
| 3 Jars, 30 × 10 cm. <sup>2</sup> (21).                    | 1 Weights for scales, 5 gm. to<br>1000 gm. <sup>3</sup>         |
| 3 Lenses (magnifiers). <sup>3</sup>                       | 3 Wing-top burners (APP., § 3 (b)).                             |
| 2 Magnets (2, etc.).                                      |   |
| 5 Pans, iron, 10 cm. <sup>3</sup>                         |   |
| 2 Retorts, stoppered, 250 cc. (37).                       |   |

LIST C — DEMONSTRATION APPARATUS. This list includes apparatus — not in other lists — needed for certain Supplementary Exercises and for the Teacher's Exercises. Numbers in parentheses refer to exercises. S means Supplementary.

- |  |  |
|--|--|
| 1 Battery (19, S 31, 32, S 32, S 33).      | 1 Condenser, Liebig, complete<br>(S 11). |
| 1 Battery jar, 12 cm. in diam.<br>(32).    | 2 Electric light bulbs (32).             |
| 1 Chlorine tube (S 17).                    | 1 Hofmann apparatus (19, S 32,<br>33).   |
| 1 Clamp (large — for condenser)<br>(S 11). | 1 Plug, glass (27).                      |

LIST D — CHEMICALS AND SUPPLIES. This list includes the quantities of chemicals and supplies needed for the exercises in this book. Unless specially marked, the quantities are sufficient for a class of ten. Numbers in parentheses refer to exercises. S means Supplementary and T means Teacher's. Starred items may be bought of a local dealer.

Acid, acetic (S 41) . . . 250 cc.	salicylic (S 41) . . . 5 gm.
hydrochloric . . . . 2.5 l.	sulfuric . . . . . 2.5 l.
nitric . . . . . 2.5 l.	Alcohol denatured <sup>5</sup> (S 47) 100 cc.
oxalic (T 8) . . . . 25 gm.	ethyl <sup>5</sup> (S 41 and LIST G) 500 cc.
pyrogallic (T 27) . . . 50 gm.	methyl (See Methanol)

<sup>1</sup> Needed in preparing solutions.

<sup>2</sup> A 500 cc. graduated cylinder may be used.

<sup>3</sup> Used frequently.

<sup>4</sup> A chemical balance costing about twenty-five dollars is sufficiently accurate. Horn pan balances, if carefully counterpoised, give acceptable results. (See APP., § 8.)

<sup>5</sup> Denatured alcohol is suitable for many experiments.

Alizarin (paste) (S 61) . . . . .	10 gm.	Cobalt nitrate (35, S 58) . . . . .	25 gm.
Alum . . . . .	250 gm.	Cochineal (S 61) . . . . .	1 gm.
Aluminum acetate (S 61) . . . . .	25 gm.	Copper borings . . . . .	200 gm.
sheet . . . . .	500 sq. cm.	bromide (35) . . . . .	25 gm.
sulfate . . . . .	250 gm.	nitrate (35) . . . . .	25 gm.
wire (41) . . . . .	10 cm.	oxide (ic) (powd.) . . . . .	100 gm.
Ammonium carbonate (S 51, etc.) . . . . .	100 gm.	sheet* . . . . .	50 sq. cm.
chloride . . . . .	250 gm.	sulfate . . . . .	500 gm.
dichromate (35) . . . . .	5 gm.	wire (No. 20)* . . . . .	250 gm.
hydroxide . . . . .	2.5 l.	wire (No. 30) (22)* . . . . .	250 gm.
molybdate (56) (See LIST G) . . . . .	25 gm.	Dextrose (See Glucose)	
nitrate (S 36) . . . . .	25 gm.	Fehling's Solution (See LIST G) . . . . .	100 cc.
oxalate . . . . .	25 gm.	Ferric chloride . . . . .	50 gm.
sulfate . . . . .	25 gm.	Ferrous sulfate . . . . .	100 gm.
sulfide . . . . .	100 cc.	sulfide . . . . .	150 gm.
Antimony chloride (31, 34) . . . . .	25 gm.	Gasolene* . . . . .	250 cc.
Asbestos, shredded (41) . . . . .	5 gm.	Glass wool (41) . . . . .	5 gm.
Baking powder (56)* . . . . .	250 gm.	Glucose . . . . .	25 gm.
Barium carbonate (59) . . . . .	25 gm.	Glycerin (T 32) . . . . .	25 cc.
chloride . . . . .	150 gm.	Gold leaf (S 20, S 23) . . . . .	1 bk.
chloride (pure) (S 30) . . . . .	25 gm.	Hydrogen peroxide* . . . . .	250 cc.
nitrate (S 33, S 59) . . . . .	25 gm.	Hydroquinone (S 60) (See LIST G) . . . . .	5 gm.
sulfate (59) . . . . .	25 gm.	Iodine . . . . .	25 gm.
Bleaching powder* (23, S 21) . . . . .	500 gm.	Iron filings . . . . .	100 gm.
Borax* . . . . .	250 gm.	powder . . . . .	150 gm.
Bromine water (S 46) . . . . .	100 cc.	thread (steel wool) . . . . .	50 gm.
Cadmium nitrate (38) . . . . .	5 gm.	Joss sticks* . . . . .	5 pkg.
Calcium (31) . . . . .	5 gm.	Lead dioxide . . . . .	50 gm.
butyrate (S 41) . . . . .	5 gm.	monoxide (litharge)* . . . . .	100 gm.
carbide (S 40) . . . . .	5 gm.	nitrate . . . . .	100 gm.
carbonate (marble)* . . . . .	2.5 kg.	tea (T 11)* . . . . .	250 sq. cm.
chloride . . . . .	100 gm.	Litmus cubes (S 32) . . . . .	5 gm.
nitrate (S 59) . . . . .	25 gm.	paper (each color) . . . . .	6 sheets
oxide (lime)* . . . . .	500 gm.	Magnesium chloride . . . . .	25 gm.
sulfate . . . . .	100 gm.	ribbon . . . . .	25 gm.
Carbon disulfide . . . . .	250 cc.	sulfate . . . . .	25 gm.
tetrachloride (S 46, S 47) . . . . .	100 cc.	Manganese dioxide (gran.) . . . . .	500 gm.
Cement* (S 54) . . . . .	100 gm.	dioxide (powd.) (41, S 44, S 47) . . . . .	100 gm.
Chalk . . . . .	25 gm.	sulfate . . . . .	25 gm.
Charcoal, animal . . . . .	100 gm.	Mercury (S 24) . . . . .	25 gm.
blocks (53, S 58) . . . . .	15 blk.	chloride (ic) . . . . .	25 gm.
lump . . . . .	15 lp.	nitrate (ous) . . . . .	25 gm.
wood (powd.) . . . . .	150 gm.	oxide (S 1) . . . . .	25 gm.
Cobalt chloride (35) . . . . .	25 gm.		

Methanol (S 41) . . . . .	25 cc.	Soda lime (S 35) . . . . .	50 gm.
Molisch's solution (See LIST G)		Sodium (S 11, S 52) . . . . .	10 gm.
Naphthol (Alpha) (See LIST G) . . . . .	10 gm.	bicarbonate* (S 7) . . . . .	250 gm.
Nickel chloride (T 35) . . . . .	25 gm.	carbonate* . . . . .	500 gm.
sulfate (T 35) . . . . .	25 gm.	chloride . . . . .	2 kg.
Phenol-phthalein solution (T 30, S 42) . . . . .	150 cc.	chloride (pure) (S 30) . . . . .	25 gm.
Phosphorus (S 5) . . . . .	5 gm.	citrate (See Fehling's Solution, LIST G) . . . . .	50 gm.
Photograph developer (S 60) (See LIST G)		dichromate (35) . . . . .	25 gm.
Plaster of Paris (S 55) . . . . .	125 gm.	hydroxide . . . . .	500 gm.
Potassium bromide (S 44, S 45, S 46) . . . . .	100 gm.	nitrate . . . . .	250 gm.
bromide (pure) (S 30) . . . . .	5 gm.	nitrite (S 27) . . . . .	25 gm.
carbonate (59) . . . . .	25 gm.	peroxide . . . . .	25 gm.
chlorate (cryst.) . . . . .	100 gm.	phosphate (disodium) . . . . .	25 gm.
chlorate (powd.) . . . . .	100 gm.	sulfate . . . . .	150 gm.
chlorate (pure) (S 30) . . . . .	5 gm.	sulfate (acid) . . . . .	10 gm.
chloride . . . . .	25 gm.	sulfite (T 44) (See also developer LIST G) . . . . .	150 gm.
chromate . . . . .	10 gm.	thiosulfate ("hypo") (S 16, S 60) . . . . .	250 gm.
dichromate . . . . .	50 gm.	Stannous chloride (See LIST G) . . . . .	25 gm.
ferricyanide . . . . .	25 gm.	Starch* . . . . .	100 gm.
ferrocyanide . . . . .	50 gm.	Strontium nitrate (pure) (S 30) . . . . .	25 gm.
hydroxide . . . . .	100 gm.	Sugar (cane)* . . . . .	250 gm.
iodide (S 47, S 48, S 50) . . . . .	75 gm.	Sulfur (powd.) . . . . .	200 gm.
nitrate (powd.) . . . . .	150 gm.	roll . . . . .	500 gm.
nitrate (pure) (S 30) . . . . .	25 gm.	Tartar emetic (S 38) . . . . .	5 gm.
permanganate (23) . . . . .	200 gm.	Turpentine* . . . . .	50 cc.
sulfate (59) . . . . .	25 gm.	Zinc chloride (S 14) . . . . .	25 gm.
sulfate (pure) (S 50) . . . . .	25 gm.	dust (4) . . . . .	50 gm.
thiocyanate . . . . .	25 gm.	granulated . . . . .	1 kg.
Sand* . . . . .	500 gm.	sheet* . . . . .	100 gm.
Silver nitrate . . . . .	50 gm.	sulfate . . . . .	100 gm.
sulfate (S 33) . . . . .	10 gm.		

LIST E — MISCELLANEOUS SUPPLIES. The quantities are usually small. Many substances are used only once. Numbers in parentheses refer to exercises. S means Supplementary. Bread, candle, candy, carbon (electric light — S 31), clay, colored and unbleached cloth, soft coal, cotton, feather, gelatin (S 35), hair, horn, iron nails, lantern slide plates (S 60), lard (S 42), leather scraps, lemon, lye (S 42), maple sugar, phosphorus tipped matches, molasses, old mortar (S 53), paper (colored, black, and



photographic — S 60), plaster (S 53), potato, quill toothpick, rice, soap, (wax) taper, thread, tooth powder (S 53), vaseline, vinegar, whiting (S 53).

LIST F — EMERGENCY SUPPLIES (see APP., § 12). 25 gm. absorbent cotton, 12 bandages (5 cm.), blanket, 50 gm. boric acid solution, 25 gm. camphor solution, 250 gm. carron oil, 12.5 gm. collodion, 1 book court plaster, fire extinguisher, 1 pkg. gauze (picric acid), medicine dropper, 1 paper pins, sand and scoop, scissors, 1 bottle smelling salts, 250 gm. sodium bicarbonate, 1 spool thread, 25 gm. vaseline.

LIST G — SOLUTIONS. The solutions needed for most exercises are approximately 10 per cent (*i.e.* 10 gm. in 100 cc. of water). The concentration of special solutions is usually given in the directions for these exercises. Certain solutions should be made as follows :

Acetic acid, dilute, 1 vol. to 5 vols. of water.

Ammonium hydroxide, 1 vol. to 3 vols. of water.

Ammonium molybdate. Dissolve 15 gm. in 100 cc. of water and pour this solution into 100 cc. of nitric acid (1 vol. acid to 1 vol. water).

Ammonium oxalate, 5 per cent.

Ammonium sulfide, 1 vol. to 1 vol. of water.

Barium chloride, 5 per cent. Use distilled water or water free from sulfates.

Calcium hydroxide. *See* Limewater.

Chlorine water. Saturate water with the gas.

Cobalt(ous) nitrate, 5 per cent.

Cochineal. Grind a little cochineal with water, dilute as desired, and filter.

Developer (photographic). Dissolve 2.7 gm. of hydroquinone, 7.6 gm. of sodium sulfite, 15 gm. of sodium carbonate, and 0.4 gm. of potassium bromide in 200 cc. of water.

Fehling's solution. Dissolve 1.73 gm. of copper sulfate (cryst.) in 15 cc. of water. Dissolve 34.6 gm. of sodium citrate and 10 gm. of sodium carbonate (anhydrous) in 85 cc. of water. Pour the first solution into the second slowly with constant stirring. The final, clear solution will keep well and is used as made. (Note this is different from the old two-volume solution.)

Ferric chloride, 5 per cent.

Ferrous sulfate, 5 per cent. Must be freshly prepared. Keep a few pieces of iron in the solution.

Hydrochloric acid, dilute, 1 vol. to 5 vols. of water.

Lead salts. Use distilled water or filter.

Limewater. Slake lime, add considerable water, shake occasionally, and siphon off the clear liquid.

Litmus. As under Cochineal.

Mercuric chloride, 5 per cent. POISON!

Mercurous nitrate, 5 per cent. Add a little mercury.

Molisch's solution. Dissolve 5 gm. of alpha-naphthol in 50 cc. of ethyl alcohol (95 per cent).

Nitric acid, dilute, 1 vol. to 5 vols. of water.

Phenol-phthalein. Dissolve 0.5 gm. in 50 cc. of alcohol and dilute slightly with water.

Potassium permanganate, 5 per cent. (Add sufficient water to obtain the "very dilute" solution.)

Potassium thiocyanate, 5 per cent.

Silver nitrate, 5 per cent. Use distilled water (or water free from chlorides).

Silver sulfate, 0.5 per cent. See Silver nitrate.

Stannous chloride. Reduce concentrated hydrochloric acid with tin, dilute with water, and keep tin in this solution.

Sulfuric acid, dilute, 1 vol. to 5 vols. of water. Pour the acid slowly into the water, stirring constantly.









LIBRARY OF CONGRESS



0 003 839 821 0

